

Engineering Specification

Job Name _____

Contractor _____

Job Location _____

Approval _____

Engineer _____

Contractor's P.O. No. _____

Approval _____

Representative _____

LEAD FREE*

Series LF709 Double Check Valve Assembly

2½" – 10"

Series LF709 Double Check valve assemblies help prevent the reverse flow of polluted water from entering into the potable water system. This series can be applied, where approved by the local authority having jurisdiction, on non-health hazard installations. The series features a modular check design concept to facilitate maintenance. Check with local jurisdictional authority as to installation requirements. The iron components of the backflow preventer are coated with ArmorTek®, a patented three-part advanced epoxy system engineered to reduce microbial-induced corrosion (MIC) and protect exposed metal substrate. The series also features Lead Free* construction to comply with Lead Free* installation requirements.

Smart and Connected technology comes standard on the Series LF709 assembly with NRS gate valves, Model IOT. The model includes sensors integrated at test cocks No. 2, No. 3, and No. 4 to measure pressure fluctuations at the three locations. This technology enables monitoring and assessment of certain aspects of backflow assembly performance and the water supply system.

NOTICE

For Model IOT, an add-on monitoring connection kit is required to collect data from the pressure sensors. Without the connection kit, the sensors are passive components that do not communicate with any other device. The add-on connection kit communicates over wired serial (RS-485) interface and is compatible with most Building Management and Building Automation Systems. (The connection kit and pressure sensors are also available for existing installations. For more information, download RP/IS-709/709DCDA.)

Features

- Simplified modular design concept to facilitate complete maintenance and assembly by retaining the spring load
- Sensors adapted to test cocks on Model IOT for measuring pressure fluctuations; activated with add-on monitoring connection kit (BMS/BAS only)
- Replaceable stainless steel seats
- Maximum flow at low pressure drop
- ArmorTek coating technology to resist corrosion of internals
- No special tools required for servicing
- Captured spring assemblies for safety
- Approved for vertical flow up installation

*The wetted surface of this product contacted by consumable water contains less than 0.25% of lead by weight.

Watts product specifications in U.S. customary units and metric are approximate and are provided for reference only. For precise measurements, please contact Watts Technical Service. Watts reserves the right to change or modify product design, construction, specifications, or materials without prior notice and without incurring any obligation to make such changes and modifications on Watts products previously or subsequently sold.



LF709-NRS-IOT

Specification

A Double Check valve assembly shall be installed at referenced cross-connections to prevent the backflow of polluted water into the potable water supply. The cross-connections shall be determined by local inspection authority for use where a high hazard situation does not exist. Valve shall feature modular check assemblies with center stem guiding. Each check module shall have a captured spring and be accessible through a bolted cover plate. Seats shall be replaceable without special tools. It shall be a complete assembly including tight-closing resilient seated shutoff valves, test cocks, and a strainer is recommended. The Lead Free* Double Check valve assembly shall comply with state codes and standards, where applicable, requiring reduced lead content. The assembly shall meet the requirements of ASSE No. 1015; AWWA C510-92; CSA B64.5 and UL Classified File No. EX3185. Approved by the Foundation for Cross-Connection Control and Hydraulic Research at the University of Southern California. Iron components of the backflow preventer shall incorporate ArmorTek coating technology, delivering integrated protection against electrochemical corrosion and microbial-induced corrosion. The assembly shall be Watts Series LF709.

NOTICE

Use of integrated pressure sensors on and monitoring connection kit with IOT models does not replace the need to comply with all required instructions, codes, and regulations related to installation, operation, and maintenance of the backflow preventer.

Watts is not responsible for data transmission failures due to power issues.

NOTICE

The information contained herein is not intended to replace the full product installation and safety information available or the experience of a trained product installer. You are required to thoroughly read all installation instructions and product safety information before beginning the installation of this product.

Inquire with governing authorities for local installation requirements.

Model/Option

NRS	Non-rising stem resilient seated gate valves
OSY	UL Classified and FM Approved outside stem and yoke resilient seated gate valves
S-FDA	FDA epoxy coated strainer
LF	Without shutoff valves
IOT	With pressure sensing IoT test cocks and NRS gate valves
QT-FDA	FDA epoxy coated quarter-turn ball valve shutoffs

Materials

Check Valve Body:	Epoxy coated cast iron
Seats:	Stainless steel
Coating:	ArmorTek powder coating, applied to internal and external surfaces

Pressure – Temperature

Temperatures Range: 33°F – 110°F (0.5°C – 43°C) continuous, 140°F (60°C) intermittent
 Maximum Working Pressure: 175 psi (12.1 bar)

Standards

AWWA C510-92
 IAPMO PA 31
 USC Manual for Cross-Connection Control, 8th Edition

Approvals



Approved by the Foundation for Cross-Connection Control and Hydraulic Research at the University of Southern California. Sizes 4" to 10" approved horizontal and vertical "flow up." Sizes 2½" and 3" approved horizontal only.

FM Approved 4" to 10" vertical "flow up" with OSY gate valves only.
 NOTE: Model "S" not listed.

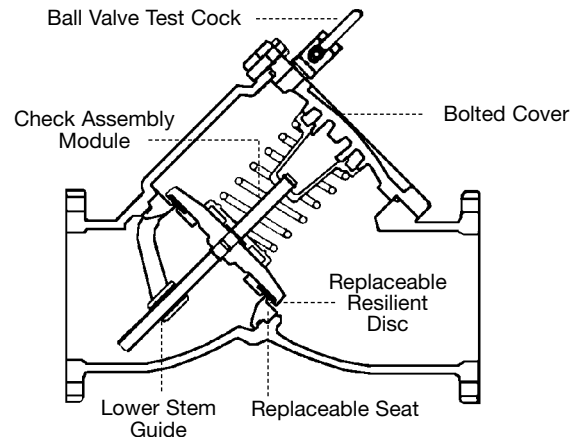

Dimensions – Weights

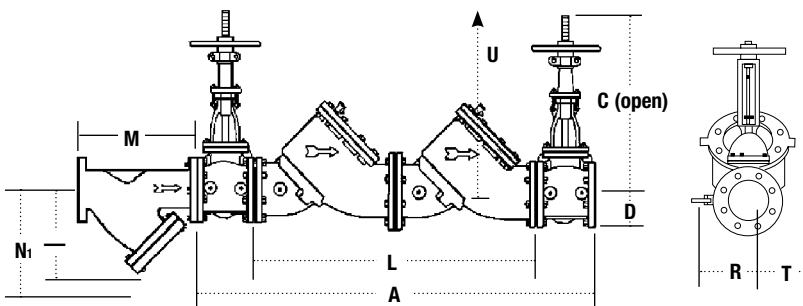

SIZE	DIMENSIONS															
	A		C (OSY)		C (NRS)		D		L		U†		M		N	
in.	in.	mm	in.	mm	in.	mm	in.	mm	in.	mm	in.	mm	in.	mm	in.	mm
2½	39 ⁷ / ₁₆	1002	16 ³ / ₈	416	9 ³ / ₈	238	3½	89	24 ⁷ / ₈	613	11	279	10	254	6½	165
3	40 ⁷ / ₁₆	1027	18 ³ / ₈	479	10¼	260	3¾	95	24 ⁷ / ₈	613	14	356	10 ¹ / ₈	257	7	178
4	52 ³ / ₈	1332	22¾	578	12 ³ / ₁₆	310	4½	114	34 ¹ / ₈	867	14	356	12 ¹ / ₈	308	8¼	210
6	62 ¹⁵ / ₁₆	1599	30 ¹ / ₈	765	16	406	5½	140	41 ⁵ / ₈	1058	16	406	18½	470	13½	343
8	75 ⁷ / ₁₆	1916	37¾	959	19 ¹⁵ / ₁₆	506	6½	165	52 ⁷ / ₈	1325	21	533	21 ⁵ / ₈	549	15½	394
10	90 ⁷ / ₁₆	2297	45¾	1162	23 ¹³ / ₁₆	605	8	203	64 ¹ / ₈	1630	25	635	26	660	18½	470

SIZE	DIMENSIONS							WEIGHT				STRAINER				
	N1††		R		R*		T		NRS		OSY		QT		Weight	
in.	in.	mm	in.	mm	in.	mm	in.	mm	lb	kg	lb	kg	lb	kg	lb	kg
2½	10	254	4	102	16	406	3	76	167	76	170	77	154	70	28	13
3	10	254	5	127	16	406	3	76	167	76	170	77	162	73	34	15
4	12	305	6	152	19¾	502	6	152	368	167	383	174	275	125	60	27
6	20	508	11	279	26	660	7½	191	627	284	707	321	611	277	122	55
8	22¾	578	11¼	286	11¼	286	9	229	1201	545	1307	593	1419	644	247	112
10	28	711	12½	318	12½	318	10¼	260	2003	909	2073	940	2466	1119	370	168

†Service clearance for check assembly from center.

††Dimension required for screen removal.

*Quarter-turn (QT) valve dimensions.

Capacity

‡Typical maximum system flow rate (7.5 ft/s)

**UL rated flow

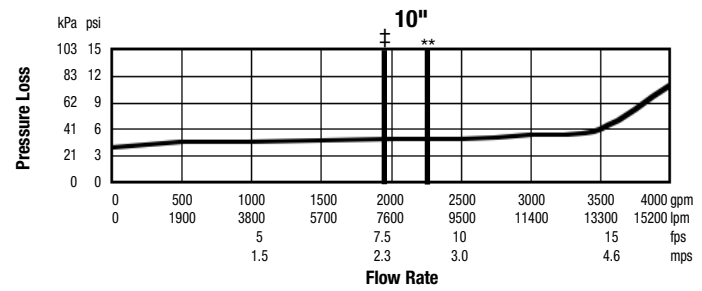
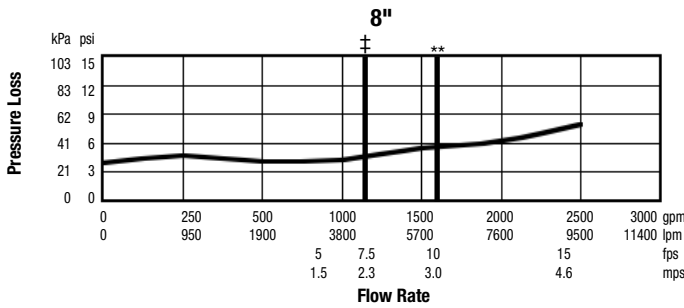
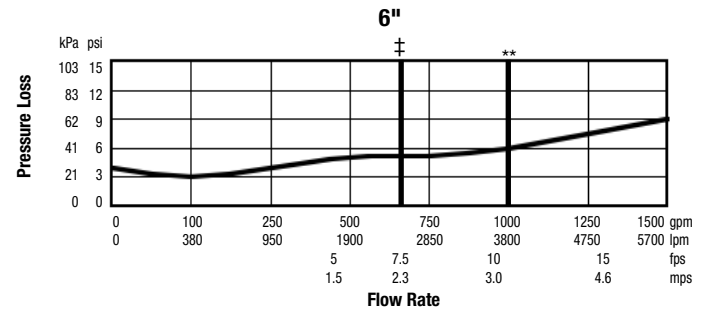
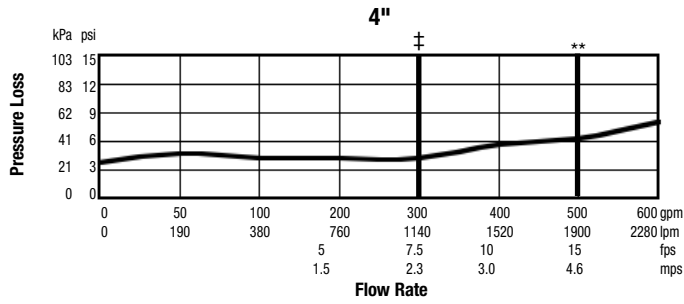
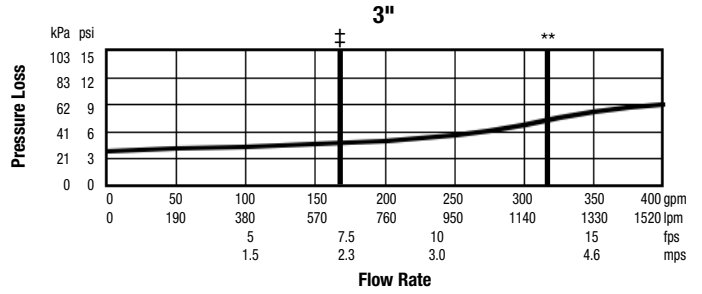
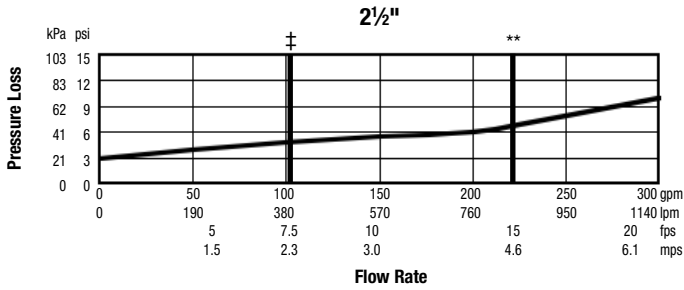

USA: T: (978) 689-6066 • Watts.com

Canada: T: (888) 208-8927 • Watts.ca

Latin America: T: (52) 55-4122-0138 • Watts.com