

Engineering Specification

Job Name _____

Contractor _____

Job Location _____

Approval _____

Engineer _____

Contractor's P.O. No. _____

Approval _____

Representative _____

LEAD FREE*

MasterSeries® Model LF880W/WZ Reduced Pressure Zone Assembly 4" – 10"

MasterSeries LF880W/WZ Reduced Pressure Zone assembly is designed to provide drop-in replacement of competitor's valves in either the N-pattern (LF886W) or Z-pattern (LF886WZ) orientation. Protects against backpressure and backsiphonage conditions for high hazard/toxic application in accordance with Local Governing Water Utility Codes. Used primarily on potable drinking water systems where Local Governing Code mandates protection from non-potable quality water being pumped or siphoned back into the potable water system.

The iron components of the backflow preventer are coated with ArmorTek®, a patented three-part advanced epoxy system engineered to reduce microbial-induced corrosion (MIC) and protect exposed metal substrate. The series features Lead Free construction to comply with low lead installation requirements. The Lead Free Reduced Pressure Zone assemblies shall comply with state codes and standards, where applicable, requiring reduced lead content.

The series include a flood sensor to detect excessive water discharges from the relief valve. The flood sensor relays a signal that triggers a multichannel alert (call, email, text) to notify personnel about potential flooding.

NOTICE

An add-on connection kit is required to activate the flood sensor. Without the connection kit, the flood sensor is a passive component that does not communicate with any other device. (A retrofit sensor connection kit is also available for existing installations. For more information, download RP/IS-F-880V-RP/RPDA.)

NOTICE

Use of the flood sensor does not replace the need to comply with all required instructions, codes, and regulations related to installation, operation, and maintenance of this product, including the need to provide proper drainage in the event of a discharge.

Watts® is not responsible for the failure of alerts due to connectivity issues, power outages, or improper installation.

*The wetted surface of this product contacted by consumable water contains less than 0.25% of lead by weight.

FEBCO product specifications in U.S. customary units and metric are approximate and are provided for reference only. For precise measurements, please contact FEBCO Technical Service. FEBCO reserves the right to change or modify product design, construction, specifications, or materials without prior notice and without incurring any obligation to make such changes and modifications on FEBCO products previously or subsequently sold.



LF880W-NRS with flood sensor

Features

- Stainless steel relief valve seat and stainless steel check components for maximum performance and durability
- Longer gate-to-gate length for drop-in replacement of longer valves
- Inline serviceable assembly; no special tools required
- Vertical up or vertical down N-pattern installation
- Vertical up Z-pattern installation
- Captured modular spring assembly; clapper check assembly
- Reversible and replaceable discs
- Field replaceable seats
- Ductile iron valve body design
- ArmorTek coating technology to resist corrosion of internals
- Modular and repairable pressure differential relief valve
- Sensor on relief valve for flood detection, activated by add-on connection kit for BMS or cellular network communication

NOTICE

The information contained herein is not intended to replace the full product installation and safety information available or the experience of a trained product installer. You are required to thoroughly read all installation instructions and product safety information before beginning the installation of this product.

Inquire with governing authorities for local installation requirements.



A WATTS Brand

Specification

FEBCO MasterSeries LF880W/WZ Reduced Pressure Zone assembly shall be installed on the potable water supply and at each point of cross-connection to protect against possible backpressure and backsiphonage conditions for high hazard/toxic applications. The assembly shall consist of a main line valve body composed of a pressure differential relief valve located in a zone between two (2) independently acting approved clapper style check modules with replaceable seats and disc rubbers. Servicing of the pressure differential relief valve and both check modules does not require any special tools; both check modules are accessed through independent top entry covers.

This assembly shall be fitted with AWWA Compliant inlet/outlet resilient seated shutoff valves; when used on a Fire-Sprinkler application, the assembly shall be fitted with UL Classified and FM Approved inlet/outlet resilient seated shutoff valves and contain four (4) properly located resilient seated test cocks as specified by AWWA Standard C511. Iron components of the backflow preventer shall incorporate ArmorTek coating technology, delivering integrated protection against electrochemical corrosion and microbial-induced corrosion. Flow and pressure loss performance parameters shall meet the requirements of AWWA Standard C511. The assembly shall be FEBCO MasterSeries LF880W/WZ and shall include a sensor on the relief valve for flood detection.

Model/Option

FS	Sensor of relief valve for flood detection
OSY	UL Classified and FM Approved OS&Y gate valves (ANSI/AWWA C515 Compliant)
NRS	Non-rising stem gate valves (ANSI/AWWA C509 Compliant)
LG	Less shutoff valves (This is NOT an APPROVED ASSEMBLY.)

Example Ordering Description

4" LF880W-OSY-FS - Valve assembly fitted with OS&Y shutoff valves and flood sensor

Available Components

Wye Strainer	FDA Approved (ASME B16.1 Class 125 & AWWA Class D Flange)
--------------	---

Approvals – Standards

- Approved by the Foundation for Cross-Connection Control and Hydraulic Research at The University of Southern California (FCCCHR USC)
- ASSE 1013 Listed
- UL Classified** (US & Canada)
- FM Approved**
- IAPMO/cUPC
- AWWA Standard C511 Compliant
- End Connections – Compliant to ASME B16.1 Class 125 & AWWA Class D Flange



Assembly Flow Orientation

Horizontal (N-Pattern 4" – 10") - Approved by FCCCHR-USC, ASSE, cULus, FM, IAPMO/cUPC

Vertical Up (Z-Pattern 4" – 10") - Approved by FCCCHR-USC, ASSE, cULus, FM, IAPMO/cUPC

**Assembly configured with UL Classified and FM Approved OS&Y RW gate valves. Less gate valve assemblies are not UL Classified and FM Approved configurations

Materials

Main Valve Body	Ductile iron Grade 65-45-12
Relief Valve Body	Ductile iron Grade 65-45-12
Coating	ArmorTek powder coating, applied to internal and external surfaces
Shutoff Valves	NRS resilient wedge gate valve AWWA C509 (Standard) OSY resilient wedge gate valve AWWA C515 (UL Classified and FM Approved)
Check Seats	Stainless steel
Relief Valve Seat	Stainless steel
Disc Holder	Stainless steel
Elastomer Disc	Silicone
Spring	Stainless steel
Clamp	AWWA C606

Pressure - Temperature

Max. Working Pressure	175 psi (12.1 bar)
Min. Working Pressure	20 psi (1.4 bar)
Hydrostatic Test Pressure	350 psi (24.1 bar)
Hydrostatic Safety Pressure	700 psi (48.3 bar)
Temperature Range	33°F – 140°F (0.5°C – 60°C) continuous

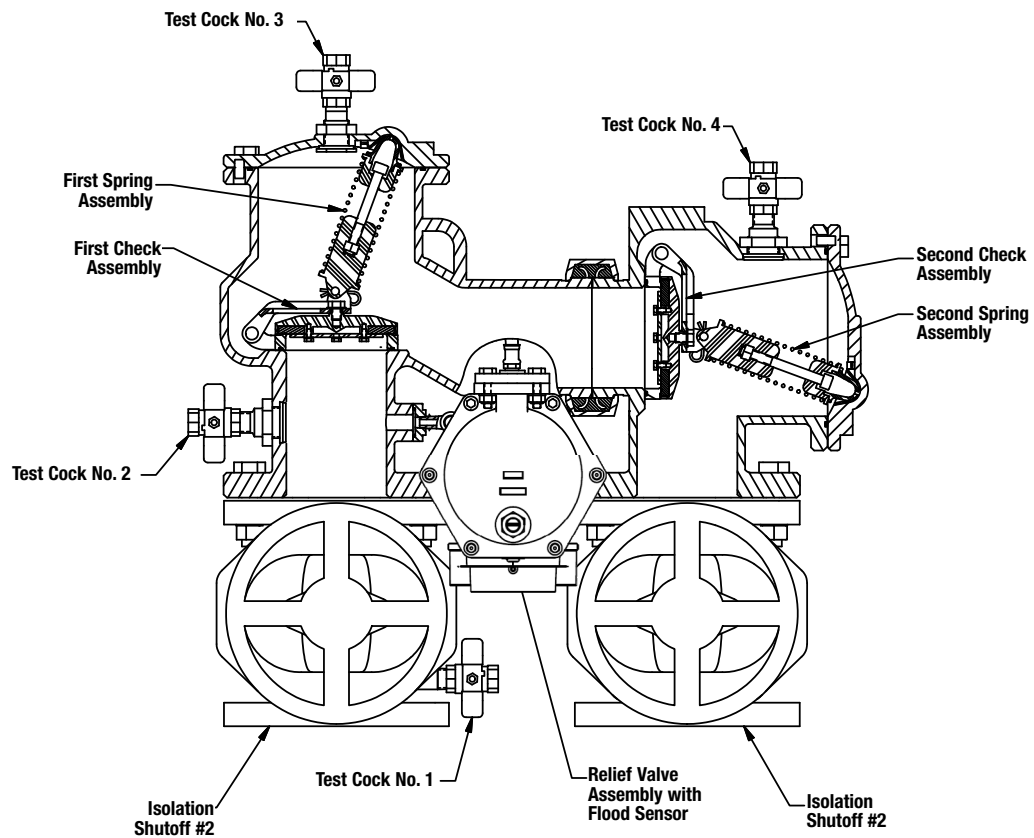

Dimensions and Weights

Below are the nominal dimensions and physical weights for LF880W/WZ, sizes 4" to 10". Allowances must be made for normal manufacturing tolerances. Download installation instructions at Watts.com, or contact your local FEBCO representative for more information.

Standard N-pattern Orientation

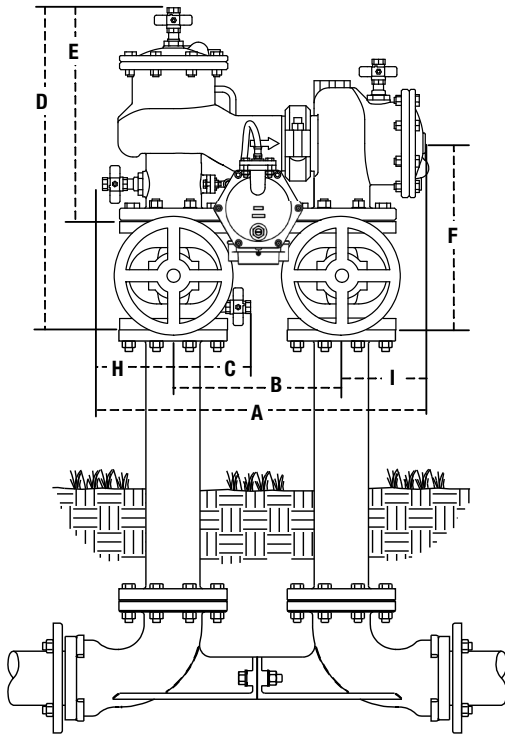

Gate Valve Side View

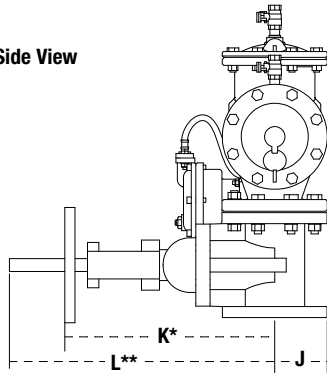

Vertical Z-pattern Orientation

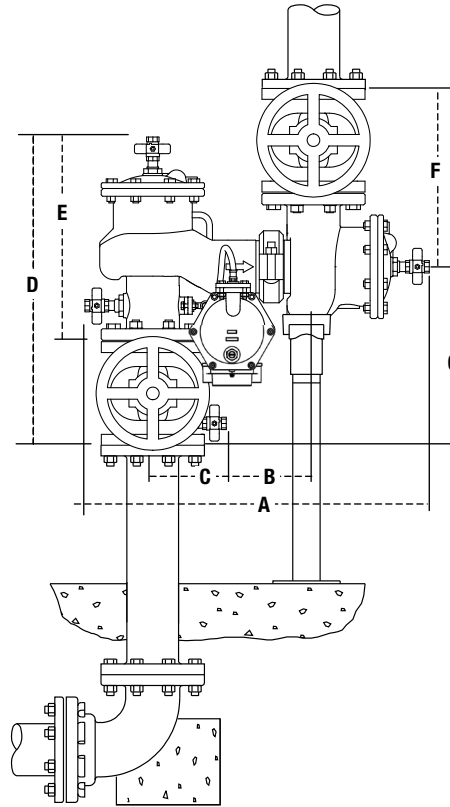

Relief Valve Detail

Relief valve with flood sensor shipped on right side (shown) field reversible to left side

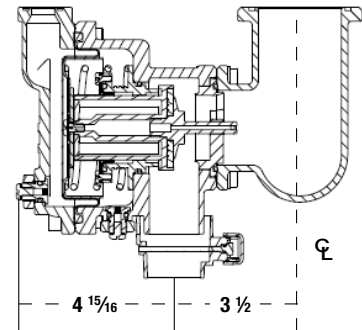

Call customer service if you need assistance with technical details.

SIZE	DIMENSIONS														WEIGHT***																	
	A (W)	A (Z)	B (W)	B (Z)	C	D	E	F	G	H	I	J	K*	L**	NRS	OSY																
in.	in.	mm	in.	mm	in.	mm	in.	mm	in.	mm	in.	mm	in.	mm	in.	mm	lb	kg	lb	kg												
4	32 ³ / ₁₆	818	32 ¹ / ₁₆	833	18 ⁵ / ₁₆	465	18 ⁵ / ₁₆	481	7	178	26 ³ / ₄	680	17 ³ / ₄	451	15 ¹ / ₂	394	31	787	6	152	7 ¹ / ₄	184	4 ¹ / ₂	114	14 ³ / ₈	365	23 ³ / ₄	591	344	156	356	162
6	34 ¹⁵ / ₁₆	887	37 ¹ / ₄	946	18 ¹ / ₁₆	475	21	533	8	203	32 ¹ / ₄	819	21 ⁵ / ₈	548	18 ⁵ / ₈	473	37 ¹ / ₄	946	7 ¹ / ₂	191	9 ¹ / ₂	241	5 ¹ / ₂	140	18 ⁷ / ₈	479	30 ³ / ₈	765	517	235	537	244
8	48	1219	49 ⁹ / ₁₆	1253	29	737	30 ³ / ₁₆	770	9 ¹ / ₄	235	36 ³ / ₈	324	24 ⁷ / ₈	632	20 ³ / ₄	527	41 ¹ / ₂	1054	8 ³ / ₄	222	10 ¹ / ₄	260	6 ³ / ₄	172	23 ¹ / ₂	597	37 ³ / ₄	959	808	366	836	379
10	50 ¹ / ₁₆	1272	51 ¹ / ₁₆	1304	29	737	30 ³ / ₁₆	533	10 ⁷ / ₁₆	264	40 ³ / ₈	1032	27 ¹ / ₂	699	23 ¹ / ₁₆	601	47 ⁷ / ₁₆	1202	9 ³ / ₈	238	11 ¹ / ₄	298	8	203	27 ¹ / ₈	699	45 ¹ / ₄	1162	-	-	1344	610

* Indicates nominal dimensions with NRS gate valves.

** Indicates nominal dimensions with OSY gate valves (full open positions).

*** Indicates weight of complete backflow assemblies with specified gate valves.

The gap drain is not designed to catch the maximum discharge possible from the relief valve. The installation of the FEBCO air gap with the drain line terminating above a floor drain handles any normal discharge or nuisance spitting through the relief valve. However, floor drain size may need to be designed to prevent water damage caused by a complete failure condition. Do not reduce the size of the drain line from the air gap fitting.

Performance

The flow capacity chart identifies valve performance based upon rated water velocity up to 20 fps.

- Maximum service flow rate is determined by maximum rated velocity of 7.5 fps.
- AWWA Manual M-22 (Appendix C) recommends that the maximum water velocity in the services be not more than 10 fps.
- UL flow rate is determined by typically rated velocity of 15 fps.

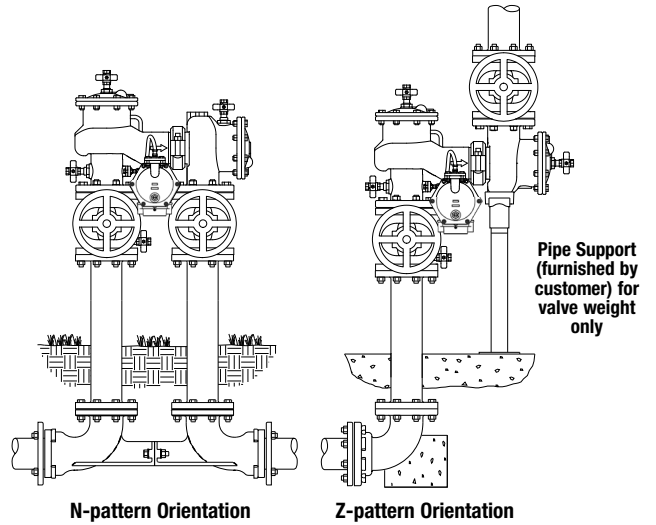

Capacity

N pattern

Z pattern

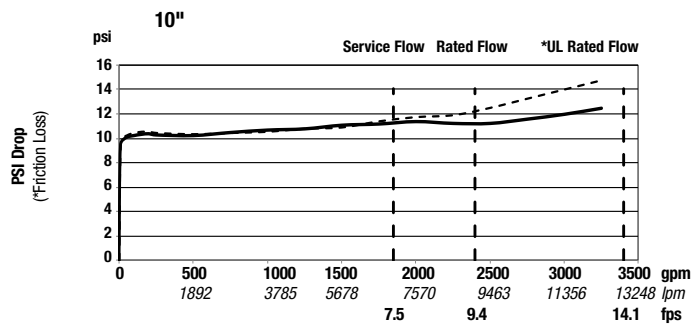
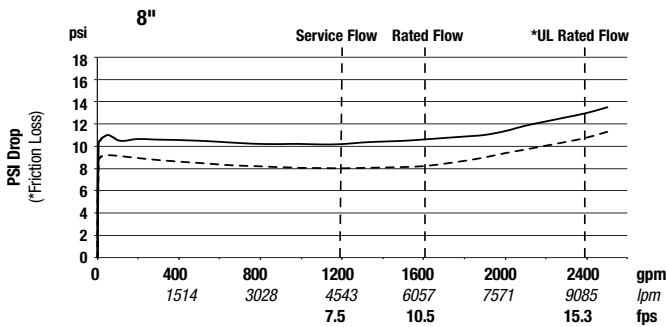
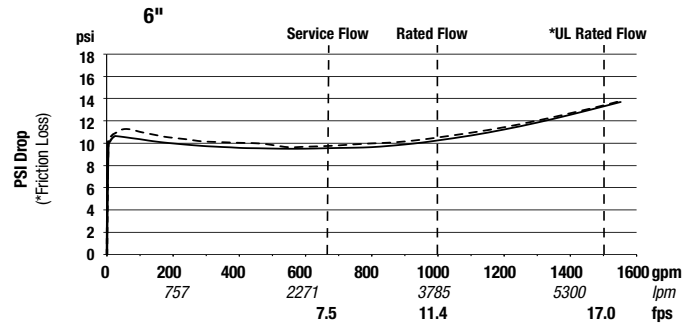
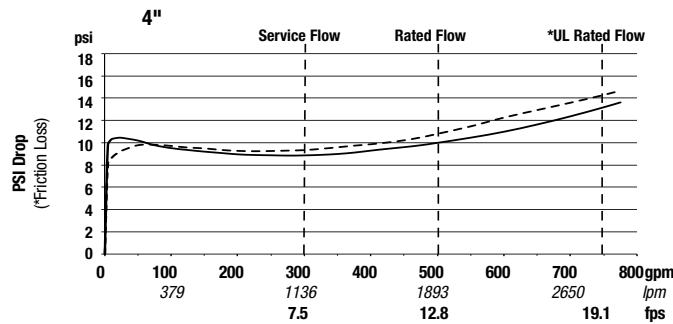

A WATTS Brand

USA: T: (800) 767-1234 • FEBCOonline.com

Canada: T: (888) 208-8927 • FEBCOonline.ca

Latin America: T: (52) 55-4122-0138 • FEBCOonline.com

