

Installation, Operation and Maintenance

Invita® Wi-Fi Thermostat



HVAC
Interface Module

Invita®
Wi-Fi Thermostat

Wall Plate

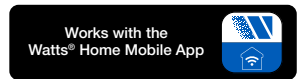

Compatible With

- Conventional systems:
2-stage heating, 2-stage cooling, fan and 2 accessories
- Heat pump systems:
4-stage heating, 2-stage cooling, fan, reversing valve and 1 accessory
- Supports dual fuel systems
- Accessory options:
Humidifier, dehumidifier, HRV/ERV ventilator, heat pump loop valve

⚠ WARNING



Please read carefully before proceeding with installation. Your failure to follow any attached instructions or operating parameters may lead to the product's failure. Keep this Manual for future reference.

tekmar®
A WATTS Brand

Table of Contents

Important Safety Information	3
Installation	4
Preparation	4
Equipment Connections	6
Wiring the HVAC Interface Module.	7
1-Stage Heat and 1-Stage Cooling with Fan	7
Up to 2-Stage Furnace and 2-Stage Air Conditioner	8
Up to 2-Stage Hydronic Boiler and 2-Stage Air Conditioner	8
Up to 2-Stage Heat Pump with Auxiliary Heat	9
Up to 2-Stage Heat Pump with 2-Stage Dual Fuel	9
Dehumidification using a DX Coil.	10
Humidifier	10
HRV/ERV Ventilator.	10
Outdoor Sensor	10
Room Sensor	11
Watts® FloodSafe® Water Detector Shutoff	11
Startup	11
Home Screen	12
Symbols	12
User Settings.	13
Away.	13
Schedule	13
Display	14
Time.	15
Fan	15
Wi-Fi.	16
Wi-Fi and Connectivity Troubleshooting.	17
Installer Settings	18
Setup	18
Setup - Toolbox	18
Setup - Temp	19
Setup - Sensors	20
Setup - Alerts	21
Setup - Relays	22–24
Setup - Humidity.	25
Setup - HRV / ERV Ventilation.	26
Sequence of Operation	27
Heating and Cooling Operation.	27–29
Relative Humidity Operation	30
HRV / ERV Ventilator Operation.	31
Heat Pump Loop Valve Operation	31
Error Messages	32–33
Technical Data	35
Limited Warranty	36

Important Safety Information

It is your responsibility to ensure that this thermostat is safely installed according to all applicable codes and standards. tekmar® is not responsible for damages resulting from improper installation and/or maintenance.



This is a safety-alert symbol. The safety alert symbol is shown alone or used with a signal word (DANGER, WARNING, or CAUTION), a pictorial and/or a safety message to identify hazards. When you see this symbol alone or with a signal word on your equipment or in this manual, be alert to the potential for death or serious personal injury.



This pictorial alerts you to electricity, electrocution, and shock hazards.

⚠ WARNING

This symbol identifies hazards which, if not avoided, could result in death or serious injury.

⚠ CAUTION

This symbol identifies hazards which, if not avoided, could result in minor or moderate injury.

NOTICE

This symbol identifies practices, actions, or failure to act which could result in property damage or damage to the equipment.

⚠ WARNING



**THINK
SAFETY
FIRST**

Read manual and all product labels BEFORE using the equipment. Do not use unless you know the safe and proper operation of this equipment. Keep this manual available for easy access by all users. Replacement manuals are available at tekmarControls.com

⚠ WARNING

- It is the installer's responsibility to ensure that this control is safely installed according to all applicable codes and standards.
- Improper installation and operation of this control could result in damage to the equipment and possibly even personal injury or death.
- This control is not intended for use as a primary limit control. Other controls that are intended and certified as safety limits must be placed into the control circuit.

NOTICE

Do not attempt to service the thermostat. There are no user serviceable parts inside the thermostat. Attempting to do so voids the warranty.

Installation

Preparation

Tools Required

- tekmar or jeweler screwdriver
- Phillips head screwdriver
- Wire stripper
- Drill (for wall anchor)
- 3/16" drill bit (for wall anchor)

Materials Required

- 18 AWG LVT Solid Wire (low voltage connections)

⚠ WARNING



Ensure power to connecting equipment is off. To prevent the risk of personal injury and/or death, make sure power is not applied to the thermostat or HVAC Interface Module until they are fully installed and ready for configuration. All work must be done with power to the circuit being worked on turned off.

NOTICE

Please be aware local codes may require this thermostat to be installed or connected by an electrician.

NOTICE

Thermostat Location

Consider the following:

- Interior wall. Keep dry. Avoid potential leakage onto the control.
- No draft, direct sun, or other cause for inaccurate temperature readings.
- Avoid installing the thermostat above a return air grille.
- Away from equipment, appliances, or other sources of electrical interference.
- Approximately 5 feet (1.5 m) off the finished floor.
- The maximum length of wire is 500 feet (150 m).

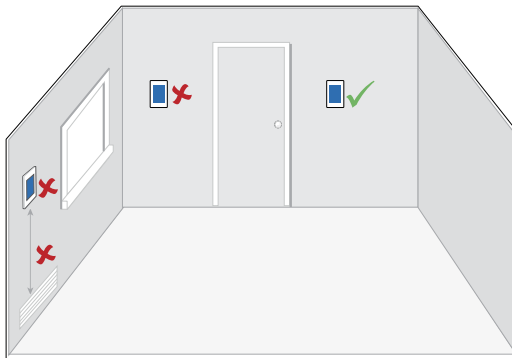

1. Remove the old thermostat

If more than 2 wires are present, identify the R & C wires for use when connecting the Invita Wi-Fi Thermostat. Additional wires should be secured in a way that prevents them from touching the circuit board or terminals on the Invita after the R & C wires are connected.

2. Mount Invita base to wall

Remove the back plate from the thermostat.

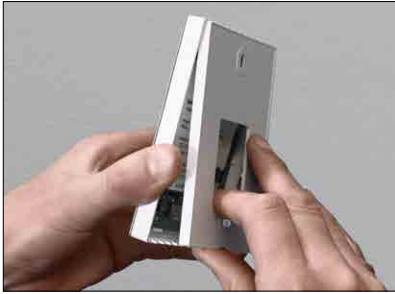

Secure the Invita thermostat back plate to a 2 x 4" electrical box with machine screws or to drywall using wood screws with wall anchors.

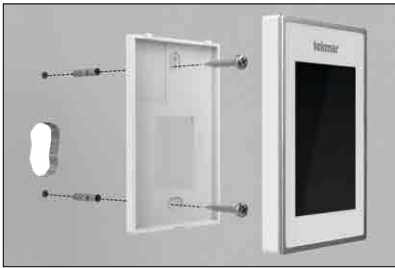

If the wall has damage extending beyond the width of the Invita Wi-Fi Thermostat, place the wall plate trim behind the back plate.



3. Wiring the Invita Wi-Fi Thermostat

Connect the 2 wires from the old thermostat to the terminals on the back of the Invita Wi-Fi Thermostat. This connection is not polarity sensitive.

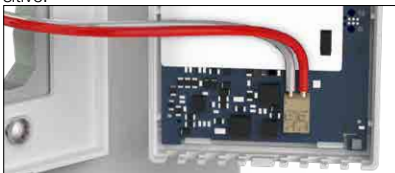

4. Attach the thermostat to back plate

Align the 2 notches at the top of the base plate with the holes on the top of the thermostat then rotate on the hinge point down to close.



5. Mounting the HVAC Interface Module

Locate the HVAC Interface Module so that it can connect to the other end of the existing wire from the thermostat. After removing the cover, secure the HVAC Interface Module to the wall, the HVAC equipment chassis or HVAC plenum using the holes at the top and bottom of the module. Wiring to the module enters from opening on the sides or the back. Refer to the diagrams on pages 6 to 11 for wiring details.



6. Replace the Cover



Push the HVAC Interface Module Cover towards the base. Top and bottom clips hold the cover in place.

Equipment Connections

This illustration shows various equipment connected to the HVAC Interface Module. Other equipment may be included in your application.

Conventional systems:

- Up to 2-stage heating, 2-stage cooling, fan and 2 accessories

Heat pump & dual fuel systems:

- Up to 4-stage heating, 2-stage cooling, fan, reversing valve and 1 accessory

Accessory options:

- Humidifier, dehumidifier, HRV/ERV ventilator

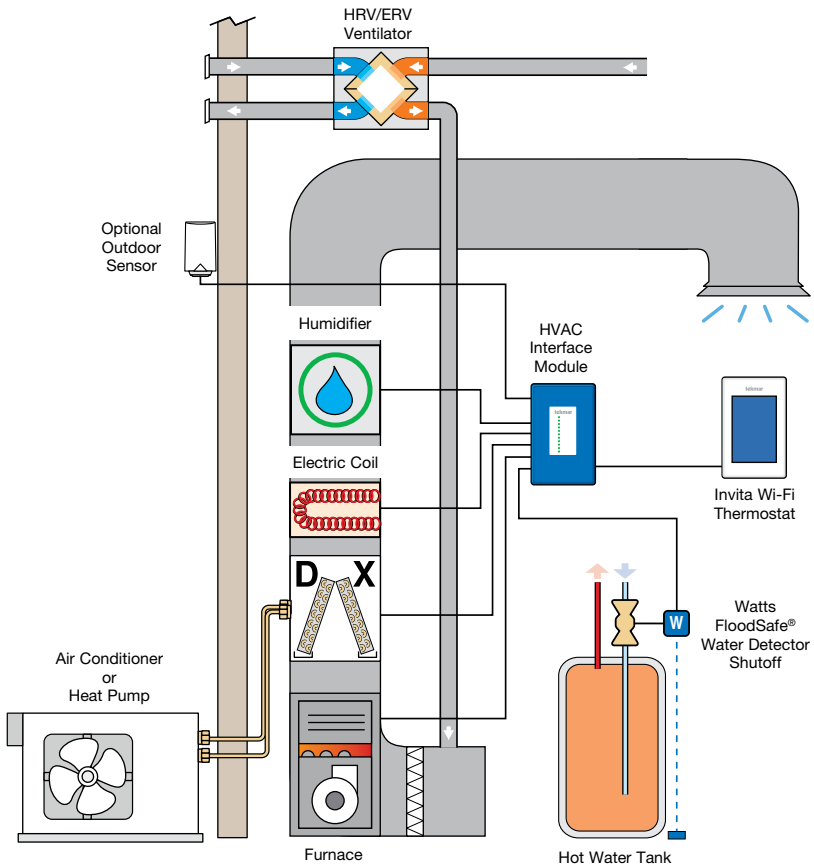

Wiring the HVAC Interface Module

⚠ WARNING



Ensure power to connecting equipment is off. To prevent the risk of personal injury and/or death, make sure power is not applied to the thermostat or HVAC Interface Module until they are fully installed and ready for configuration. All work must be done with power to the circuit being worked on turned off.

The HVAC Interface Module includes three relay power jumper connectors. These are used to provide power between terminals when necessary.

- Set Jumper J1 to On to connect power R to the Rc terminal.
- Set Jumper J2 to On to connect power R to the Rh2 wiring terminal.
- Set Jumper J3 to On connects power R to the Rh1 wiring terminal.
- Set the jumper to off to disconnect the power from Rh1, Rh2, or Rc respectively.

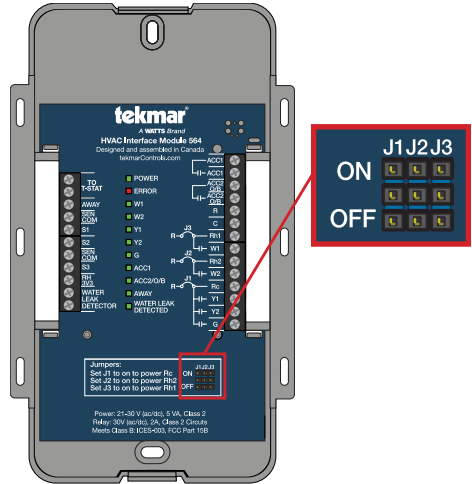

1-Stage Heat and 1-Stage Cooling with Fan

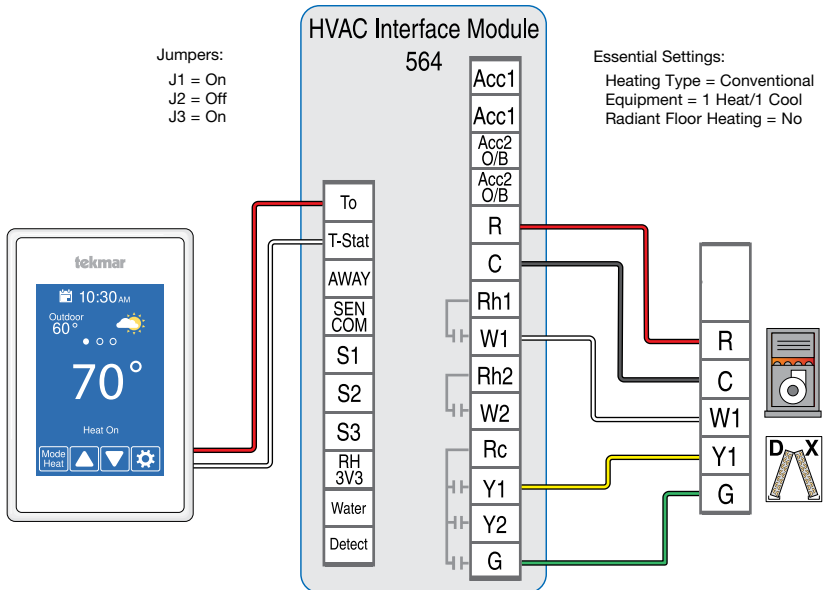

Up to 2-Stage Furnace and 2-Stage Air Conditioner

Essential Settings:

Heating Type = Conventional
 Equipment = 2 Heat/2 Cool
 Radiant Floor Heating = No

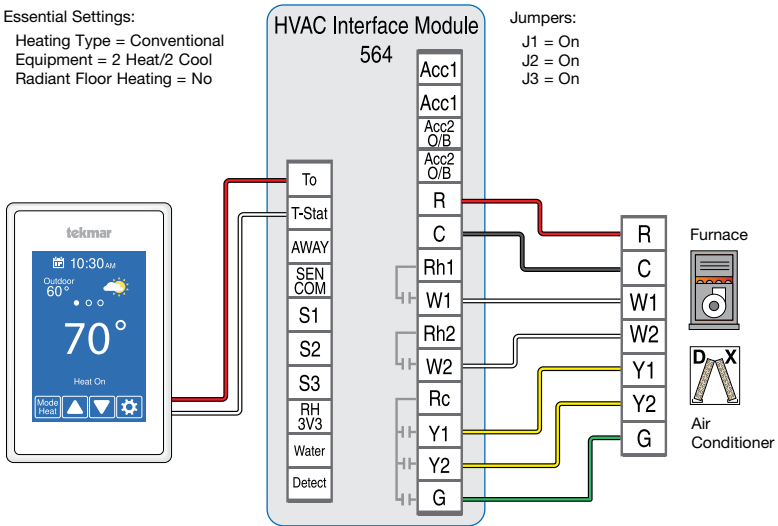

Up to 2-Stage Hydronic Boiler and 2-Stage Air Conditioner

Essential Settings:

Heating Type = Conventional
 Equipment = 2 Heat/2 Cool
 Radiant Floor Heating = Yes

Jumpers:

J1 = Off
 J2 = On
 J3 = On

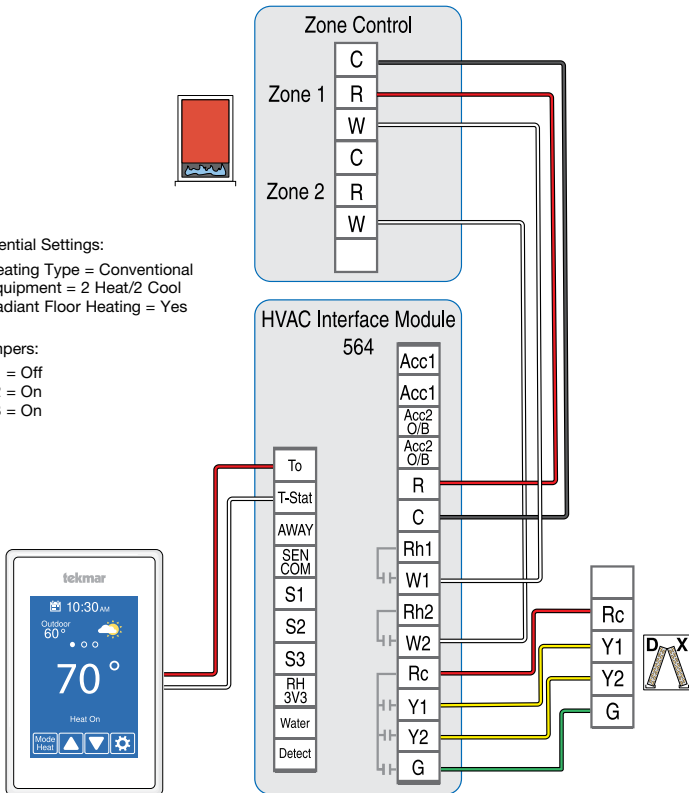

Up to 2-Stage Heat Pump with Auxiliary Heat

The thermostat operates high cost electric resistance heat when the heat pump is unable to meet the building heating load.

Essential Settings:

Heating Type = Heat Pump
 Equipment = 2 Heat Pump/1 Aux
 Radiant Floor Heating = No

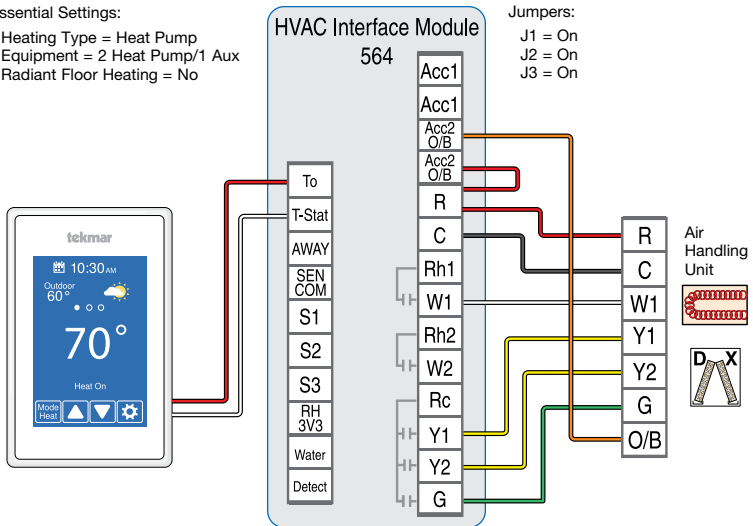

Up to 2-Stage Heat Pump with 2-Stage Dual Fuel

The thermostat operates the heat pump when the outdoor temperature is above the balance point setting and switches to the furnace when below.

Essential Settings:

Heating Type = Heat Pump
 Equipment = 2 Heat Pump/2 Aux
 Radiant Floor Heating = No

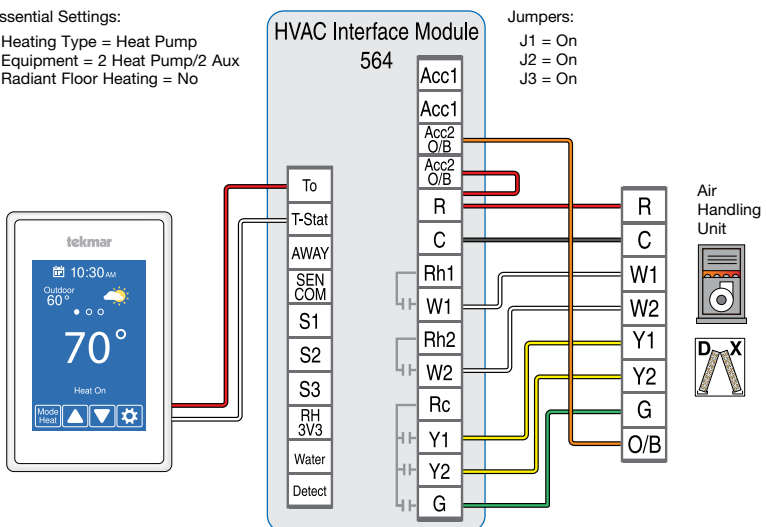

Dehumidification using a DX Coil

The thermostat operates the cooling system and runs the system fan at low speed to dehumidify the air.

Essential Settings:

Accessory Relay 1 or 2 = Dehumidifier
Dehumidifier Type = DX Coil

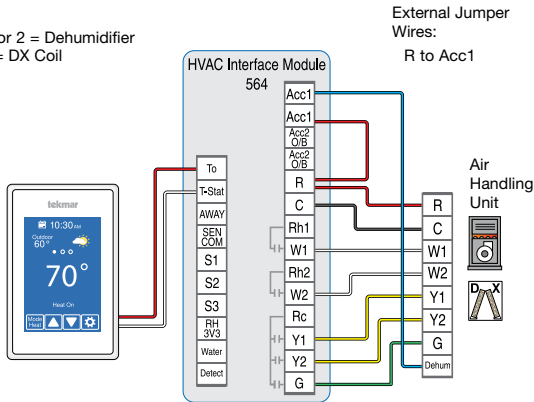

Humidifier

The thermostat operates a humidifier to increase relative humidity.

Essential Settings:

Accessory Relay 1 or 2 = Humidifier

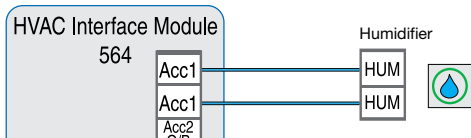

HRV/ERV Ventilator

The Heat Recovery Ventilator (HRV) or Energy Recovery Ventilator (ERV) operates to improve indoor air quality and recovers heat from exhaust air.

Essential Settings:

Accessory Relay 1 = Ventilation

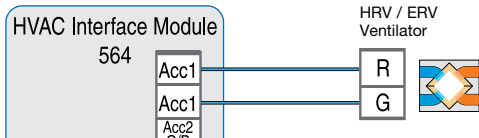

Outdoor Sensor

- Installing an outdoor sensor provides more accurate outdoor temperature readings compared to using the weather information from the Internet which may cause delays in updating weather.
- Outdoor temperature is displayed on home screen.
- Used to enable heat pump dual fuel switchover, warm weather shut down, and cold weather shut down.

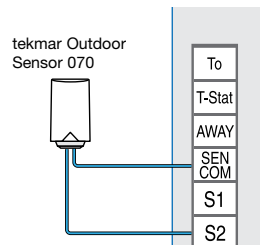

Room Sensor

When the location of the thermostat is not ideal for accurate temperature and humidity measurement, an optional room sensor can be installed in a better location. The 086 mounts flush to a wall, blending in with the room decor.

- Remotely measure the temperature and relative humidity
- The Invita Wi-Fi Thermostat provides the option to disable the internal temperature and relative humidity sensor, and use the external sensor instead.
- When using more than 1 room sensor the 564 will read the average of all the room sensors.

tekmar Humidity & Temperature Sensor 086

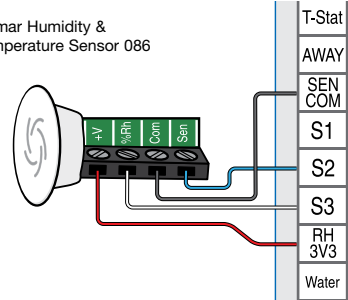

FloodSafe® Water Detector Shutoff

The Watts FloodSafe Water Detector Shutoff LFWDS prevents catastrophic water damage in the event of a water heater leak.

The thermostat provides an email notification in the event that the FloodSafe Water Detector Shutoff LFWDS detects a water and shuts off the supply line to the water heater.

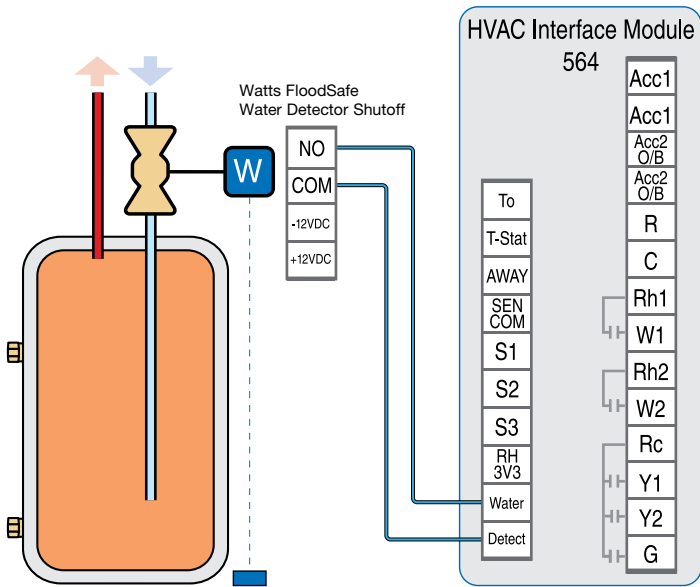

Startup

Restore power to the connected equipment. Once energized, the Invita Wi-Fi Thermostat will display the home screen.

Home Screen

After 60 seconds of inactivity, the thermostat home screen displays only the time and the temperature.

Go to schedule

Swipe to view:

- Weather
- Outdoor temperature
- Floor temperature
- Heat To setting
- Cool To setting
- Relative Humidity

Humidifier or Dehumidifier operation

Change operating mode

Current time

Outdoor 60°

Floor 70°

Current temperature

Equipment operation Heat, Cool and Fan On

Go to settings

Mode

Emergency Heat

Heat

Cool

Auto Heat-Cool

Off

Save Cancel

'Save to schedule' applies the new temperature to the current schedule event.

Touch ▲ or ▼ to adjust temperatures

Select either Heat To or Cool To

Temperature Adjustment

Heat To 70

Cool To 75

Hold Until 5:00 PM

Save to Schedule

MENU SELECTION

AWAY SCHEDULE

DISPLAY TIME

WIFI SETUP

← FAN

WIFI: Connected

Hold overrides the programmed schedule until the time shown

Symbols



The fan is on



The dehumidifier is on



Ok setting change



The humidifier is on



The info button provides a description of the setting



Cancel setting change

User Settings

Away

Use the Away setting to save energy when the building is unoccupied

Operates normally At Home
Operates using the Away temperature selected in the Setup menu Away

Save

Info

- Selecting the Away setting on a thermostat or the mobile app will affect all devices linked to that location through the app.
- The Away temperature can be adjusted in the Setup / Temps menu.

Schedule

Current group of program days.

Schedule
Mon Tue Wed Thu Fri

Go to the next group of program days.

Wake	6:00 AM	70°	75°
Leave	8:00 AM	65°	78°
Return	6:00 PM	70°	75°
Sleep	10:00 PM	65°	78°
Early Start	On	Schedule	On
<input checked="" type="checkbox"/>	New Schedule	<input type="checkbox"/>	<input type="checkbox"/>

Heating temperature

Cooling temperature

Early Start anticipates the time required to heat or cool a room and starts early.

Set to On to follow the schedule. Set to Off to use the same temperature all of the time.

Creates a new schedule.

Set schedule start time

Set heating temperature

Set cooling temperature

Schedule Setup Mon Tue Wed Thu Fri			
Wake	<input checked="" type="radio"/> On <input type="radio"/> Skip		
6:00 AM			
Heat to 70°			
Cool to 75°			
<input checked="" type="checkbox"/>	<input type="checkbox"/>	<input type="checkbox"/>	<input type="checkbox"/>

Select skip if you don't want a temperature change.

Display

Setting	Range	Default
TEMPERATURE UNITS Select °F or °C.	°F or °C	°F
ENERGY USE View the number of hours the heating or cooling has operated either daily or monthly.	0 to 24 (daily) 0 to 744 (monthly)	0 hours

Daily Usage

Today	0 hrs	0 hrs
Yesterday	0 hrs	0 hrs
Tue	0 hrs	0 hrs
Mon	0 hrs	0 hrs
Sun	0 hrs	0 hrs
Sat	0 hrs	0 hrs
Fri	0 hrs	0 hrs

Monthly Usage ⓘ

View each day's run time for both heating and cooling.

Toggle between Daily and Monthly Usage.

Setting	Range	Default
BRIGHTNESS ACTIVE Select the brightness when touching the screen.	30 to 100%	100%
BRIGHTNESS INACTIVE Select the brightness when not in use.	Off, 30 to 100%	50%
BACKGROUND Select the background color.	Light, Blue, Night, Latte, Espresso	Blue
LANGUAGE Select the language.	English, Español, Français	English
SCREEN CLEAN Locks screen for 10 seconds to allow cleaning.	N/A	N/A
INACTIVE TIME DISPLAY Select if the time is visible when the display is inactive.	Off or On	On
INACTIVE HUMIDITY DISPLAY Select if the humidity is visible when the display is inactive.	Off or On	Off
INACTIVE OUTDOOR DISPLAY Select if the outdoor temperature is visible when the display is inactive.	Off or On	Off

Time

When connected to the Internet, the time can be set automatically.

NOTICE

Incorrectly setting the time and date manually may prevent the thermostat from communicating to the mobile app. Automatic time source is recommended when using an Internet connection.

The time and date can be manually set by highlighting a field and then using the ▲ or ▼ buttons.

Choose from the time options listed below.

Setting	Range	Default
TIME FORMAT Select the time format.	12 or 24 hour	12 hour
TIME SOURCE If Internet is available, the time source can be either automatically or manually set.	Automatic, Manual	Auto
TIME ZONE Select the local time zone.	Hawaii, Alaska, Pacific, Mountain, Central, Eastern, Atlantic, Newfoundland	Eastern
DAYLIGHT SAVING TIME Select the brightness when not in use.	Off, On	On

Fan

The fan is normally off when set to auto but turns on when needed for the heating or cooling equipment.

When a programmable schedule is used, there is a fan setting for each time period.

Wi-Fi

NOTICE

Before using the Wi-Fi features of this product, you must accept the Terms of Use, as amended from time to time and available at [Watts.com/terms-of-use](https://www.watts.com/terms-of-use). If you do not accept these terms, this product can still be used without Wi-Fi features.

The thermostat includes a step by step tutorial to setup the Wi-Fi connection.

Tutorial

Before first using Wi-Fi features of this product, you must accept the Terms of Use available at <https://www.watts.com/terms-of-use> by pressing AGREE below.

If you do not accept these terms, this product can still be used without Wi-Fi features.

DISAGREE AGREE

Step 1

Agree to Terms of Use

Wi-Fi

Off

On

NEXT

Step 2

Turn on Wi-Fi

NETWORK SSID

Select a network from the list:

Your House

← CONNECT

Step 3

Enter wireless network name. It must support WPA2 security encryption.

Enter Password

A	B	C	D	E	F
G	H	I	J	K	L
M	N	O	P	Q	R
S	T	U	V	W	X
Y	Z		Shft	A/1	Del

← CONNECT

Step 4

Enter Wi-Fi password.

ZIP/Postal

1	2	3	4	5	6
7	8	9	0	-	/
:	;	()	\$	&
@	*	.	,	?	!
'	\		Shft	A/1	Del

OK

Step 5

Enter ZIP or postal code. This determines your location for weather information.

Time Source

Automatic

Manual

NEXT

Step 6

Select if the time is set automatically from the Internet or manually.

Wi-Fi and Connectivity Troubleshooting

Wi-Fi Connection Status

Press  > Wi-Fi > Wi-Fi:On >  to view the thermostat connection status.

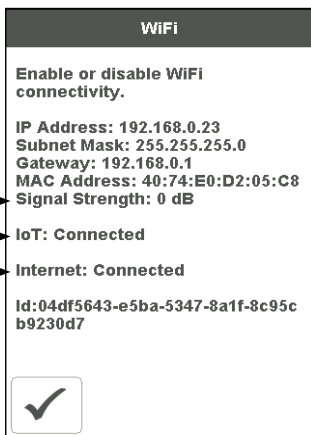

(1) Wi-Fi Signal Strength

- The Wi-Fi signal must measure between 0 and -69 dB to have a reliable connection to the Watts cloud.
- A Wi-Fi extender is recommended to be installed if the Wi-Fi signal is between -70 to -100 dB.

(2) Internet Connected

- The Wi-Fi information screen will show Internet Connected when the thermostat is connected to the router and there is a connection to the Internet.

(3) IoT Connected

- The thermostat connection status will show IoT Connected when connected to the Watts Cloud and the thermostat is ready to be registered to the app.

If IoT is not connected, please follow these steps:

Check Password

- Double check that you are using the correct Wi-Fi network and password.
- The password is limited to 32 characters, and can include upper and lower case letters, numbers, special characters and spaces. A space counts as a character.
- The thermostat supports WPA2-Personal password security.

Power Off and On

- Power the thermostat off. Next, power the router off, wait 10 seconds, then power on and wait for the Internet status to be on. Then power the thermostat on.

Check Router & Firewall

Consult the router manual or Internet Service Provider (ISP) for assistance with router setup with these configurations:

- The router must provide a 2.4 GHz signal. The thermostat is not compatible with 5 GHz networks.
- The router is using WPA2-Personal security.
- The router has DHCP enabled with enough available addresses for all Internet devices.
- The router firewall is not blocking the outbound UDP or TCP ports: 53, 123, 443, 8883.
- The router firewall is not blocking connections to *.azure-devices.net
- The router firewall is not blocking the thermostat based upon a MAC filter list.

Create a Wi-Fi Hotspot

If you are unable to connect to the Wi-Fi network, try creating a Wi-Fi Hotspot on your mobile device to bypass the router.

Apple* iOS Wi-Fi hotspot instructions
<https://support.apple.com/en-us/HT204023>

Android** Wi-Fi hotspot instructions
<https://support.google.com/android/answer/9059108>

If the thermostat displays IoT connected when using the Wi-Fi Hotspot, please contact your Internet Service Provider (ISP) or IT professional for assistance with the router.

* Apple and App Store are trademarks of Apple Inc.

** Google, Android and Google Play are trademarks of Google LLC.

Installer Settings

Setup

The Setup menu contains seven sub-menus that determine how the thermostat operates.

The Access Level setting in the Toolbox menu determines how many settings are available to the user.

Press back to return to the main Settings menu.

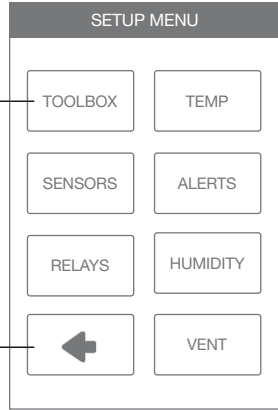

Setup - Toolbox

Setting	Range	Default
ERROR Displays any error messages.	N/A	N/A
ACCESS LEVEL Select between user and installer access levels. User access level restricts access in the Setup Menu.	User, Installer	Installer
STATUS The current status of warm weather shut down, cold weather shut down and each of the relays.	Early Start, WWSD, CWSD, W1, W2, Y1, Y2, G, Acc1, Acc2	N/A
SOFTWARE VERSION Display the software version.	N/A	N/A
LOAD DEFAULTS All settings are returned to factory defaults.	Yes, No	No
CALIBRATE TOUCHSCREEN Recalibrate the screen after loading factory defaults.	N/A	N/A

Setup - Temp

Setting	Range	Default
<i>Screen Page 1</i>		
FLOOR MIN - WAKE Select the floor temperature while in the wake schedule. Applies when there is both a floor and an air sensor.	Off, 40 to 95°F Off, 4.5 to 35.0°C	Off
FLOOR MIN - LEAVE Select the floor temperature while in the leave schedule. Applies when there is both a floor and an air sensor.	Off, 40 to 95°F Off, 4.5 to 35.0°C	Off
FLOOR MIN - RETURN Select the floor temperature while in the return schedule. Applies when there is both a floor and an air sensor.	Off, 40 to 95°F Off, 4.5 to 35.0°C	Off
FLOOR MIN - SLEEP Select the floor temperature while in the sleep schedule. Applies when there is both a floor and an air sensor.	Off, 40 to 95°F Off, 4.5 to 35.0°C	Off
FLOOR MIN - AWAY Select the floor temperature while in away. Applies when there is both a floor and an air sensor.	Off, 40 to 95°F Off, 4.5 to 35.0°C	Off
FLOOR MAX Select the maximum floor temperature. This protects the floor covering from over heating. Applies when there is a floor sensor.	Off, 40 to 95°F Off, 4.5 to 35.0°C	Off
<i>Screen Page 2</i>		
HEAT TO AWAY Select the heating temperature when away.	Off, 40 to 95°F Off, 4.5 to 35.0°C	62°F 16.5°C
HEAT TO MIN LIMIT Select the minimum heating temperature limit.	Off, 40 to 95°F Off, 4.5 to 35.0°C	Off
HEAT TO MAX LIMIT Select the maximum heating temperature limit.	Off, 40 to 95°F Off, 4.5 to 35.0°C	Off
COOL TO AWAY Select the cooling temperature when away.	Off, 45 to 100°F Off, 7.0 to 38.0°C	Off
COOL TO MIN LIMIT Select the minimum cooling temperature limit.	Off, 45 to 100°F Off, 7.0 to 38.0°C	Off
COOL TO MAX LIMIT Select the maximum cooling temperature limit.	Off, 45 to 100°F Off, 7.0 to 38.0°C	Off
<i>Screen Page 3</i>		
WARM WEATHER SHUT DOWN Select the outdoor temperature at which the heating is shut off.	Off, 40 to 100°F Off, 4.5 to 38.0°C	Off
COLD WEATHER SHUT DOWN Select the outdoor temperature at which the cooling is shut off.	Off, 40 to 100°F Off, 4.5 to 38.0°C	Off
HEAT PUMP BALANCE POINT Select the outdoor temperature at which the heat pump is shut off and the backup heat source is operated exclusively.	Off, -22 to 70°F Off, -30.0 to 21.0°C	Off

Setup - Sensors

Setting	Range	Default
SENSOR 1 Select the type of sensor connected to S1 and Com wiring terminals.	Off, Room, Floor	Off
SENSOR 2 Select the type of sensor connected to S2 and Com wiring terminals.	Off, Room, Floor, Outdoor	Off
SENSOR 3 Select the type of sensor connected to S3 and Com wiring terminals.	Off, Room, Floor, Humidity	Off
INTERNAL ROOM SENSOR Select if the internal room temperature sensor is on or off. Sensor 1, 2 or 3 is set to room.	Off, On	On
INTERNAL HUMIDITY SENSOR Select if the internal humidity sensor is on or off. Only available when Sensor 3 is set to read an external humidity sensor.	Off, On	On
ROOM OFFSET Manual offset correction of the room temperature measurement.	Off, -5 to +5°F -3.0 to 3.0°C	Off
FLOOR OFFSET Manual offset correction of the floor temperature measurement.	Off, -5 to +5°F -3.0 to 3.0°C	Off
HUMIDITY OFFSET Manual offset correction of the relative humidity measurement.	Off, -10% to +10%	Off

Setup - Alerts

Setting	Range	Default
ROOM HOT WARNING Sends a notification if the room exceeds this temperature.	Off, 40 to 100°F Off, 4.5 to 38.0°C	Off
ROOM COLD WARNING Sends a notification if the room falls below this temperature.	Off, 40 to 100°F Off, 4.5 to 38.0°C	Off
LOW HUMIDITY WARNING Sends a notification if the humidity falls below this setting.	Off, 5 to 95%	Off
HIGH HUMIDITY WARNING Sends a notification if the humidity rises above this setting.	Off, 5 to 95%	Off
AUXILIARY HEAT RUN TIME WARNING Sends a notification if the auxiliary heat W1 or W2 runs continuously for longer than this setting. This setting only applies for heat pump systems.	Off, 1 to 24 hours	Off
AIR FILTER CHANGE WARNING Sends a notification to change the air filter when the fan exceeds this run time.	Off, 200 to 2000 hours	Off
UV LAMP CHANGE WARNING Sends a notification to change the UV disinfectant lamp when it exceeds this run time.	Off, 10,000 to 50,000 hours	Off
ALERT INPUT TYPE Sends a notification when the Alert Input (Water Detect) is made. A predefined message will be sent based on setting selected.	Water Leak ERV Heat Pump Boiler Sump Pump Service Needed	Water Leak

Setup - Relays (1 of 3)

Setting	Range	Default
HEATING TYPE Select between conventional heating or heat pump.	Conventional, Heat Pump	Conventional
EQUIPMENT Select the number of stages of the heating and cooling equipment.	Conventional 1 Heat/1 Cool, 1 Heat/2 Cool, 2 Heat/1 Cool, 2 Heat/2 Cool,	1 Heat/ 1 Cool
	Heat Pump 1 HP, 1 HP/1 Aux, 1 HP/2 Aux, 2 HP, 2 HP/1 Aux, 2 HP/2 Aux	1 HP/1 Aux
RADIANT FLOOR HEATING Select if the first stage W1 heats a radiant floor.	Yes or No	No
HEAT 1 DIFFERENTIAL Select when the first stage heating turns on. Turn on point is the Heat To setting minus the differential.	0.9 to 2.0°F 0.5 to 1.05°C	1.4°F 0.75°C
HEAT 2 DIFFERENTIAL Select when the second stage heating turns on. Turn on point is the Heat To setting minus the differential. This setting is available when there are at least 2 heating stages.	1.0 to 10.0°F 0.6 to 5.6°C	2.0°F 1.2°C
HEAT 2 DELAY Select the time delay when the second stage heating turns on. The time delay starts counting after the first stage heating is turned on. This setting is available when there are at least 2 heating stages.	0 to 180 minutes	1 minute
HEAT 3 DIFFERENTIAL Select when the third stage heating turns on. Turn on point is the Heat To setting minus the differential. This setting is available when a heat pump is selected and there are at least 3 heating stages.	1.0 to 10.0°F 0.6 to 5.6°C	2.5°F 1.4°C
HEAT 3 DELAY Select the time delay when the third stage heating turns on. The time delay starts counting after the second stage heating is turned on. This setting is available when a heat pump is selected and there are at least 3 heating stages.	0 to 180 minutes	1 minute
HEAT 4 DIFFERENTIAL Select when the fourth stage heating turns on. Turn on point is the Heat To setting minus the differential. This setting is available when a heat pump is selected and there are 4 heating stages.	1.0 to 10.0°F 0.6 to 5.6°C	3.0°F 1.8°C

Setup - Relays (2 of 3)

Setting	Range	Default
HEAT 4 DELAY Select the time delay when the fourth stage heating turns on. The time delay starts counting after the third stage heating is turned on. This setting is available when a heat pump is selected and there are at least 4 heating stages.	0 to 180 minutes	1 minute
COOL 1 DIFFERENTIAL Select when the first stage cooling turns on. Turn on point is the Cool To setting plus the differential.	0.9 to 2.0°F 0.5 to 1.05°C	1.4°F 0.75°C
COOL 2 DIFFERENTIAL Select when the second stage cooling turns on. Turn on point is the Cool To setting plus the differential. This setting is available when there are two cooling stages.	1.0 to 10.0°F 0.6 to 5.6°C	2.0°F 1.2°C
COOL 2 DELAY Select the time delay when the second stage cooling turns on. The delay time starts counting after the first stage cooling is turned on. This setting is available when there are two cooling stages.	0 to 180 minutes	1 minute
Y MIN RUN TIME Select the minimum time the cooling compressor must run before shutting off. This helps prevent compressor failure.	0:30 to 10:00 minutes	2:00 minutes
Y MIN OFF TIME Select the minimum time the cooling compressor must be off before turning back on. This helps prevent compressor failure.	0:30 to 10:00 minutes	5:00 minutes
DUAL FUEL Select dual fuel on if the heat pump has 100% backup using a furnace or hydronic fan coil. The setting is available for heat pump systems with auxiliary heat.	Off or On	Off
ACCESSORY RELAY 1 Select the type of equipment that the accessory relay 1 operates.	Off, Humidifier, Dehumidifier, Ventilation, HP Loop Valve	Off
ACCESSORY RELAY 2 Select the type of equipment that the accessory relay 2 operates. This setting is only available for conventional heating systems.	Off, Humidifier, Dehumidifier	Off

Setup - Relays (3 of 3)

Setting	Range	Default
<p>HEAT PUMP REVERSING VALVE</p> <p>Select O for heat pumps designed for normally heating operation. Select B for heat pumps designed for normally cooling operation. This setting is only available for heat pump systems.</p>	O (Orange), B (Blue)	O
<p>FAN RELAY</p> <p>Select which relays require fan operation. Combinations with W1 are not available when Radiant Floor Heating is set to yes.</p>	G only, With Y With Y and W1, With Y and W2, With Y, W1 and W2	G only
<p>FAN WITH HRV/ERV</p> <p>Select if the HRV or HVAC system fan should turn on together with the HRV or ERV ventilation fan.</p>	Off or On	Off
<p>HUMIDIFIER TYPE</p> <p>Select the type of humidifier. This setting is available when Accessory 1 or 2 is set to Humidifier.</p>	Evaporative, Steam, Stand Alone	Steam
<p>WINDOW PROTECTION</p> <p>Select if the relative humidity setpoint should automatically adjust with outdoor temperature to prevent frost on windows. This setting is available when Accessory 1 or 2 is set to Humidifier and the outdoor temperature is available (via sensor or internet).</p>	Off or On	Off
<p>WINDOW QUALITY</p> <p>The window quality determines the amount that the relative humidity setting is lowered during cold outdoor weather. Choose the highest number of panes installed and best quality as a starting point. If window condensation appears, lower the setting until condensation stops forming. This setting is available when Accessory 1 or 2 is set to Humidifier and a wired outdoor sensor is installed.</p>	1 Pane 2 Pane 3 Pane Poor Average Better	2 Pane Average
<p>DEHUMIDIFIER TYPE</p> <p>Select the type of dehumidifier. This setting is available when Accessory 1 or 2 is set to Dehumidifier.</p>	DX Coil, Stand Alone	DX Coil
<p>HEAT-COOL TIME INTERLOCK</p> <p>When operating in Mode Auto, select the amount of time to wait between switching from heating to cooling and vice versa.</p>	10 to 180 minutes	10 minutes
<p>WARM FLOOR DURING COOLING</p> <p>Select whether the floor should be heated when in cooling mode. This setting is only available when Radiant Floor Heating is set to yes.</p>	Yes or No	No

Setup - Humidity

Set the lowest relative humidity level.

Range is 10 to 80%

Default is 40%

Available when Accessory 1 or 2 operates a humidifier.

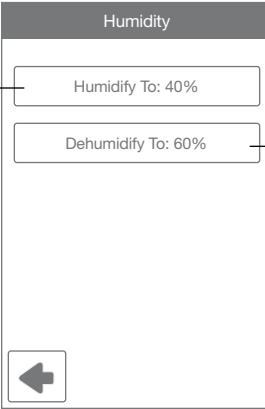

The image shows a mobile application screen titled "Humidity". It features two input fields: "Humidify To: 40%" and "Dehumidify To: 60%". A back arrow icon is located in the bottom-left corner. Two lines with arrows point from the text on either side of the screen to the respective input fields.

Set the highest relative humidity level.

Range is 20 to 90%

Default is 60%

Available when Accessory 1 or 2 operates a dehumidifier.

Setup - HRV / ERV Ventilation

VENTILATION FAN

Wake	30 min/hr
Leave	Auto
Return	45 min/hr
Sleep	Auto

When a programmable schedule is used, there is a ventilation setting for each time period.

The ventilation fan runs for the set amount of time per hour.

VENTILATION Wake

On
45 min/hr
30 min/hr
15 min/hr
Off

Sequence of Operation

Heating and Cooling Operation

- The heating setpoint can be set from 40 to 95°F (4.5 to 35°C).
- The Heat On symbol is shown on the display when the thermostat is heating.
- The cooling setpoint can be set from 45 to 100°F (7.0 to 38.0°C).
- Heating for freeze protection is provided whenever the air or floor temperature falls below 40°F (4.5°C), regardless of operating mode.
- The Cool On symbol is shown on the display when the thermostat is cooling.
- After heat call there will be a 30sec fan post purge.

The thermostat supports two heating system types: 1) conventional, or 2) heat pump.

Conventional Systems

A conventional heating system includes: furnaces, air conditioners, hydronic heating systems with baseboards, radiant floors, or fan coils and electric heating.

The thermostat supports up to two heating stages, two cooling stages, a fan and two accessory relays.

EQUIPMENT SETTING	1H/1C	1H/2C	2H/1C	2H/2C
First stage heating	W1	W1	W1	W1
Second stage heating	-	-	W2	W2
First stage cooling	Y1	Y1	Y1	Y1
Second stage cooling	-	Y2	-	Y2
Fan	G			
Accessory 1	Choice of: Humidifier, Dehumidifier, HRV/ERV			
Accessory 2	Choice of: Humidifier, Dehumidifier			

Heat Pump Systems no Radiant Floor

A heat pump system may include additional heat sources as backup. The thermostat supports up to four heating stages, two cooling stages, a reversing valve, a fan and one accessory relay.

EQUIPMENT SETTING	1HP	1HP/1AUX	1HP/2AUX	2HP	2HP/1AUX	2HP/2AUX
First stage heating	Y1	Y1	Y1	Y1	Y1	Y1
Second stage heating	-	W1	W1	Y2	Y2	Y2
Third stage heating	-	-	W2	-	W1	W1
Fourth stage heating	-	-	-	-	-	W2
First stage cooling	Y1	Y1	Y1	Y1	Y1	Y1
Second stage cooling	-	-	-	Y2	Y2	Y2
Fan	G					
Accessory 1	Choice of: Humidifier, Dehumidifier, HRV/ERV ventilator					
Accessory 2	Reversing valve O relay remains closed during cooling. Reversing valve B relay remains closed during heating.					

Heat Pump Systems with Radiant Floor

When radiant floor heating is installed, it is always the first stage of heating, followed by the heat pump, and lastly any backup heating. This allows the floor to remain warm in the heating season.

EQUIPMENT SETTING	1HP	1HP/1AUX	1HP/2AUX	2HP	2HP/1AUX	2HP/2AUX
First stage heating	Y1	W1	W1	Y1	W1	W1
Second stage heating	-	Y1	Y1	Y2	Y1	Y1
Third stage heating	-	-	W2	-	Y2	Y2
Fourth stage heating	-	-	-	-	-	W2
First stage cooling	Y1	Y1	Y1	Y1	Y1	Y1
Second stage cooling	-	-	-	Y2	Y2	Y2
Fan	G					
Accessory 1	Choice of: Humidifier, Dehumidifier, HRV/ERV ventilator					
Accessory 2	Reversing valve O or B. O relay remains closed during cooling operation. B relay remains closed during heating operation.					

When outdoor temperature is below balance point the Heat 1 differential is used to determine when second stage is turned on if configured.

Emergency Heat

For systems with heat pumps, the thermostat includes an Emergency Heat mode. This mode shuts off the heat pump Y1 and Y2 relays and operates the auxiliary heat, which is usually more expensive. Select Emergency Heat if the heat pump will not operate due to refrigerant pressure lockout condition.

Heating Differentials

Each heating stage has an adjustable differential and time delay setting to determine when the stage turns on. The heating stages Heat 4 to Heat 1 shut off are when they reach 1.5, 1.0, 0.5, and 0.0°F (0.75, 0.5, 0.25, and 0.0°C) of the Heat To setting respectively.

Radiant Floor Heating

Radiant floor heating is operated differently than other heating types due to the large time delays to heat and cool the slab. When Radiant Floor Heating is selected in the setup menu, the W1 relay operates using Pulse Width Modulation. This improves comfort for radiant systems with high mass floors.

- 100% on time at Heat To setting -1.5°F
- 50% on time at Heat To setting
- 0% on time at Heat To setting + 1.5°F

Room Sensor and Averaging

The thermostat can measure room temperature between -46 to 212°F (-43 to 100°C). The room temperature can be measured using a combination of the built-in and auxiliary sensors.

- Built-in room sensor only
- Built-in room sensor with auxiliary room sensor(s) (temperature is averaged)
- Auxiliary room sensor only

Floor Sensor for Radiant Floor Heating

The thermostat can measure floor temperature between -46 to 212°F (-43 to 100°C). If a floor sensor is connected, floor minimum and maximum settings are available. The floor heating setpoint is adjustable from 40 to 95°F (4.5 to 35°C).

For a combination of air and floor temperature control, leave the internal air sensor on in the setup menu. A floor minimum can be used to prevent a fast drop in temperature caused by receding solar exposure. This operation is recommended for areas heated by afternoon sun through large windows. When the sun sets, it can take a long time for the floors to get warm again. This may cause the room to cool off too much in the early evening. A floor minimum setting can help with this condition by maintaining a floor minimum temperature. Keep in mind the floor minimum temperature will override the air temperature, and if set too high, may overheat the room.

A floor maximum is recommended for rooms with hardwood floors. Setting floor minimum and maximum temperatures is a way of enhancing the comfort of the living space while protecting floor coverings.

If there are more than one floor temperature sensors, the temperature is averaged.

It's possible to heat a radiant floor while the cooling system is operating. This is desirable in locations such as kitchens and bathrooms. To use this feature, set the Warm Floor During Cooling on.

Cooling Differentials

The first and second stage cooling have adjustable differentials and time delay setting to determine when the stage turns on, and shut off when the room temperature reaches 0.5 and 0.0°F (0.25 and 0.0°C) above the Cool To setting respectively.

Heat Pump Balance Point

An air source heat pump's Coefficient of Performance (COP) declines with falling outdoor air temperature. The Balance Point is the outdoor temperature at which it is more economical to shut off the heat pump (relays Y1 and Y2) and operate the backup heating equipment (relays W1 and W2).

Dual Fuel

Dual fuel systems include a heat pump together with a backup heat source such as a furnace or a hydronic fan coil. When Dual Fuel is set to on, the heat pump (relays Y1 and Y2) is shut off whenever the backup heating equipment (relays W1 and W2) is operating.

If using outdoor sensor and there is a faulty outdoor sensor or the internet is offline for more than 12 hours the thermostat will operate the heat pump. To use backup the user must select emergency heat

When using internet for outdoor temperature if the internet is off line for less than 12 hours the thermostat will use the last received temperature for the balance point

Use of outdoor sensor recommended when using Dual Fuel

Warm Weather Shut Down (WWSD)

The heating system can automatically shut off based upon the outdoor temperature and the WWSD setting. This provides a convenient way to shut off the heating system.

Cold Weather Shut Down (CWSD)

The cooling system can automatically shut off based upon the outdoor temperature and CWSD setting. This prevents unwanted cooling during the winter.

Relative Humidity Operation

Relative Humidity Sensor

The thermostat includes an internal relative humidity (RH) sensor and has the option to connect to an external RH sensor. The installer has the option to disable the internal RH sensor when an external RH sensor is installed. When both the internal and external RH sensors are enabled, the RH reading is averaged.

Humidifier Operation

The thermostat controls the relative humidity (RH) by operating either the Accessory 1 or Accessory 2 relays. This is an installer configurable setting. When the RH is below the Humidify To setting by 3%, the Accessory 1 or 2 relay is closed to operate a humidifier. The humidifier is shut off when the RH reaches the Humidify To setting.

The thermostat can operate 3 types of humidifiers:

- Stand Alone
 - The humidifier is not connected to the HVAC system.
 - The thermostat Mode can be set to Heat, Cool, Auto or Off.
- Steam
 - The steam humidifier is ducted to the HVAC system.
 - The thermostat Mode can be set to Heat, Cool, Auto or Off.
 - Requires the system fan to turn on when operating.
- Evaporative
 - A drum style humidifier which requires the heating system to operate to evaporate the water.
 - This system requires the system fan to operate.
 - The thermostat Mode must be set to Heat or Auto.

Humidifier Window Protection

During cold weather, condensation will form on windows when the relative humidity (RH) is too high. The optional window protection feature automatically calculates the indoor dew point based upon the outdoor temperature and the quality of the windows installed. The humidifier is then operated to the highest possible RH that is below the Humidify To setting. This feature requires that the outdoor temperature be available (via sensor or internet).

Dehumidifier Operation

The thermostat controls the relative humidity (RH) by operating either the Accessory 1 or Accessory 2 relay. This is an installer configurable setting. When the RH is above the Dehumidify To setting by 3%, the Accessory 1 or 2 relay is closed to operate the dehumidifier. The dehumidifier is shut off when the RH reaches the Dehumidify To setting.

The thermostat can operate 2 types of dehumidifiers:

- Stand Alone
 - The dehumidifier is not connected to the HVAC system.
 - The thermostat Mode can be set to Heat, Cool, Auto or Off.
- DX Coil
 - The HVAC cooling system is used for dehumidification.
 - The Accessory 1 or Accessory 2 relay activates the DHUM operation on the air handling unit to operate the system fan at low speed.
 - The cooling compressor Y1 and Y2 relays are operated. The chilled DX coil condenses moisture from the air.
 - The cooling system can over cool the room temperature by 2°F (1°C) during dehumidification.
 - Stand Alone only operates ACC relay
 - DX Coil requires a cooling call to operate ACC, Y1 and Y2 relays.

HRV / ERV Ventilator Operation

Ventilation with fresh outdoor air is important for maintaining indoor air quality. The thermostat can operate a heat recovery ventilator (HRV) or energy recovery ventilator (ERV) on a timer by closing the Accessory 1 relay to operate the ventilator fan at low speed.

Heat Pump Loop Valve Operation

The thermostat supports water-to-air heat pump systems that absorb or reject heat to a hydronic building loop. Whenever the heat pump compressor Y1 or Y2 relay is turned on, the Accessory 1 relay closes to open a hydronic zone valve. This allows variable speed pumps on the hydronic loop to operate at lower speeds when the heat pump is off, thereby saving electrical energy.

Error Messages

When an error occurs an email notification will be sent to the registered mobile account owner.

Description
<p>COMMUNICATION ERROR</p> <p>Communication between the display module and the HVAC Interface Module is interrupted. This error clears automatically once communication is re-established.</p> <p>This error can occur if the power supply voltage to the HVAC Interface Module is low. Check the voltage with a volt meter and that the transformer VA rating is enough to power all the equipment.</p>
<p>MEMORY ERROR</p> <p>The thermostat memory settings are corrupted. To clear, load the factory defaults in the Toolbox menu. The thermostat will not operate any heating or cooling equipment while this error message is present.</p>
<p>INTERNAL ROOM SENSOR FAULT</p> <p>Due to an open or short circuit, the thermostat is unable to read the internal room temperature sensor. If sensor 1, 2 or 3 is set to room the thermostat continues to operate, otherwise operation stops.</p> <p>The error cannot be field repaired. Contact your tekmar sales representative for warranty or repair procedures.</p>
<p>INTERNAL HUMIDITY SENSOR FAULT</p> <p>Due to an open or short circuit, the thermostat is unable to read the internal humidity sensor. The thermostat stops controlling the humidifier or dehumidifier unless an external humidity sensor is installed on Sensor 3.</p> <p>The error cannot be field repaired. Contact your tekmar sales representative for warranty or repair procedures.</p>
<p>SENSOR 1 FAULT</p> <p>Due to an open or short circuit, the thermostat is unable to read the sensor wired to S1 and Com. The thermostat stops normal operation if sensor 1 is the only active room or floor sensor or if a floor maximum temperature has been set.</p> <p>Check the auxiliary sensor wire for short circuits according to the sensor installation manual. It may be necessary to replace the auxiliary sensor. Once the error has been corrected, the error message automatically clears.</p>
<p>SENSOR 2 FAULT</p> <p>Due to an open or short circuit, the thermostat is unable to read the sensor wired to S2 and Com. The thermostat stops normal operation if sensor 2 is the only active room or floor sensor or if a floor maximum temperature has been set.</p> <p>Check the auxiliary sensor wire for short circuits according to the sensor installation manual. It may be necessary to replace the auxiliary sensor. Once the error has been corrected, the error message automatically clears.</p>
<p>SENSOR 3 FAULT</p> <p>Due to an open or short circuit, the thermostat is unable to read the sensor wired to S3 and Com. The thermostat stops normal operation if sensor 3 is the only active room sensor or if a floor maximum temperature has been set.</p> <p>Check the auxiliary sensor wire for short circuits according to the sensor installation manual. It may be necessary to replace the auxiliary sensor. Once the error has been corrected, the error message automatically clears.</p>
<p>INTERNET UNAVAILABLE</p> <p>The thermostat has a Wi-Fi connection to the router but is unable to communicate to the Internet. Steps to clear the error include: 1) power off and on the router, 2) power off and on the thermostat.</p>

Description
<p>WATER LEAK DETECTOR WARNING</p> <p>A water leak has been detected and the water line has been shut off (if auto shutoff is available). The warning will automatically clear once the water leak detector has been reset.</p>
<p>ERV FAULT WARNING</p> <p>A fault has been detected with the ERV and requires attention. The warning will clear automatically once the ERV fault has been reset.</p>
<p>HEAT PUMP WARNING</p> <p>A fault has been detected with the heat pump. The warning will clear automatically once the heat pump fault has been reset.</p>
<p>BOILER WARNING</p> <p>A fault has been detected with the boiler. The warning will clear automatically once the boiler fault has been reset.</p>
<p>SUMP PUMP WARNING</p> <p>The water level has risen and activated the sump pump. Inspect the water level and the warning will clear automatically once the water level has dropped and reset.</p>
<p>SERVICE NEEDED WARNING</p> <p>A third party device has triggered a warning. The warning will clear automatically once the third party device has been reset.</p>
<p>ROOM HOT WARNING</p> <p>The room temperature is above the Room Hot Warning setting in the Alerts menu. The warning will automatically clear once the room temperature falls below the setting.</p>
<p>ROOM COLD WARNING</p> <p>The room temperature is below the Room Cold Warning setting in the Alerts menu. The warning will automatically clear once the room temperature rises above the setting.</p>
<p>LOW HUMIDITY WARNING</p> <p>The relative humidity is below the Low Humidity Warning setting in the Alerts menu. The warning will automatically clear once the relative humidity rises above the setting.</p>
<p>HIGH HUMIDITY WARNING</p> <p>The relative humidity is above the High Humidity Warning setting in the Alerts menu. The warning will automatically clear once the relative humidity falls below the setting.</p>
<p>AUXILIARY HEAT RUN TIME WARNING</p> <p>The auxiliary heat has been operating continuously longer than the Aux Heat Run Time Warning setting in the Alerts menu. The error clears when the auxiliary heat turns off. There may be problem with your heat pump. Contact your heating professional for service.</p>
<p>CHANGE AIR FILTER WARNING</p> <p>The fan run time has exceeded the Change Air Filter setting in the Alerts menu and requires replacement. To clear the warning, press the Air Filter Replaced button.</p>
<p>CHANGE UV LAMP WARNING</p> <p>The UV lamp run time has exceeded the UV Lamp setting in the Alerts menu and requires replacement. To clear the warning, press the UV Lamp Replaced button.</p>
<p>ZIP/POSTAL CODE ERROR</p> <p>The thermostat was unable to locate the ZIP or Postal Code entered in the Wi-Fi menu. Please try again with a ZIP or Postal Code of a nearby area.</p>

Technical Data

Invita® Wi-Fi Thermostat 564	
Literature	Submittal, Installation Operation Manual, User Manual, Job Record, Watts Home Manual
Packaged weight	1.3 lb. (600 g)
Dimensions	Display: 4½" H x 2¾" W x ⅞" D (114 x 70 x 14 mm) HVAC Interface Module: 7⅞" H x 4⅞" W x 1¼" D (188 x 112 x 31 mm)
Display	3.5" color touchscreen
Enclosure	Display: White PVC plastic, NEMA type 1 HVAC Interface Module: Blue PVC plastic, NEMA type 1
Approvals	Meets Class B: ICES & FCC Part 15, Energy Star
Ambient conditions	Display: Indoor use only, -4 to 122°F (-20 to 50°C), RH ≤90% non-condensing HVAC Interface Module: -40 to 122°F (-40 to 50°C), RH ≤90% non-condensing, outdoor use requires mounting in a NEMA 3 enclosure
Environmental	Do not use in presence of ammonia (animal barns).
Power supply	21-30 V (ac), 6 VA, Class 2
Relays	30 V (ac) 2 A, Class 2 Circuits
Humidity sensor	0 to 90% ±4% RH
RH Output	3.3 V (dc) humidity sensor power, 3.0 mA maximum
Temperature sensor	NTC thermistor, 10 kΩ @ 77°F (25°C ±0.2°C) β=3892
Optional sensors	tekmar type # 070, 072, 073, 076, 077, 079, 084, 086, 087
Communications	Wi-Fi 802.11n, 2.4 GHz, WPA2 encryption
Mobile app	Apple iOS 12 or higher, Android 10 or higher
Languages	English/Français/Español
Warranty	3 Year Limited Warranty

Limited Warranty and Product Return Procedure

Limited Warranty *The liability of tekmar under this warranty is limited. The Purchaser, by taking receipt of any tekmar product ("Product"), acknowledges the terms of the Limited Warranty in effect at the time of such Product sale and acknowledges that it has read and understands same.*

The tekmar Limited Warranty to the Purchaser on the Products sold hereunder is a manufacturer's pass-through warranty which the Purchaser is authorized to pass through to its customers. Under the Limited Warranty, each tekmar Product is warranted against defects in workmanship and materials if the Product is installed and used in compliance with tekmar's instructions, ordinary wear and tear excepted. The pass-through warranty period is for a period of twenty-four (24) months from the production date if the Product is not installed during that period, or twelve (12) months from the documented date of installation if installed within twenty-four (24) months from the production date.

The liability of tekmar under the Limited Warranty shall be limited to, at tekmar's sole discretion: the cost of parts and labor provided by tekmar to repair defects in materials and / or workmanship of the defective product; or to the exchange of the defective product for a warranty replacement product; or to the granting of credit limited to the original cost of the defective product, and such repair, exchange or credit shall be the sole remedy available from tekmar, and, without limiting the foregoing in any way, tekmar is not responsible, in contract, tort or strict product liability, for any other losses, costs, expenses, inconveniences, or damages, whether direct, indirect, special, secondary, incidental or consequential, arising from ownership or use of the product, or from defects in workmanship or materials, including any liability for fundamental breach of contract.

The pass-through Limited Warranty applies only to those defective Products returned to tekmar during the warranty period. This Limited Warranty does not cover the cost of the parts or labor to remove or transport the defective Product, or to reinstall the repaired or replacement Product, all such costs and expenses being subject to Purchaser's agreement and warranty with its customers.

Any representations or warranties about the Products made by Purchaser to its customers which are different from or in excess of the tekmar Limited Warranty are the Purchaser's sole responsibility and obligation. Purchaser shall indemnify and hold tekmar harmless from and against any and all claims, liabilities and damages of any kind or nature which arise out of or are related to any such representations or warranties by Purchaser to its customers.

The pass-through Limited Warranty does not apply if the returned Product has been damaged by negligence by persons other than tekmar, accident, fire, Act of God, abuse or misuse; or has been damaged by modifications, alterations or attachments made subsequent to purchase which have not been authorized by tekmar; or if the Product was not installed in compliance with tekmar's instructions and / or the local codes and ordinances; or if due to defective installation of the Product; or if the Product was not used in compliance with tekmar's instructions.

THIS WARRANTY IS IN LIEU OF ALL OTHER WARRANTIES, EXPRESS OR IMPLIED, WHICH THE GOVERNING LAW ALLOWS PARTIES TO CONTRACTUALLY EXCLUDE, INCLUDING, WITHOUT LIMITATION, IMPLIED WARRANTIES OF MERCHANTABILITY AND FITNESS FOR A PARTICULAR PURPOSE, DURABILITY OR DESCRIPTION OF THE PRODUCT, ITS NON-INFRINGEMENT OF ANY RELEVANT PATENTS OR TRADEMARKS, AND ITS COMPLIANCE WITH OR NON-VIOLATION OF ANY APPLICABLE ENVIRONMENTAL, HEALTH OR SAFETY LEGISLATION; THE TERM OF ANY OTHER WARRANTY NOT HEREBY CONTRACTUALLY EXCLUDED IS LIMITED SUCH THAT IT SHALL NOT EXTEND BEYOND TWENTY-FOUR (24) MONTHS FROM THE PRODUCTION DATE, TO THE EXTENT THAT SUCH LIMITATION IS ALLOWED BY THE GOVERNING LAW.

Product Warranty Return Procedure All Products that are believed to have defects in workmanship or materials must be returned, together with a written description of the defect, to the tekmar Representative assigned to the territory in which such Product is located. If tekmar receives an inquiry from someone other than a tekmar Representative, including an inquiry from Purchaser (if not a tekmar Representative) or Purchaser's customers, regarding a potential warranty claim, tekmar's sole obligation shall be to provide the address and other contact information regarding the appropriate Representative.

Need help? Go to our website or contact us.

tekmarControls.com | tekmar.customerservice@wattswater.com | 1-800-438-3903

tekmar[®]

A WATTS Brand

All specifications are subject to change without notice

Tel: 1-800-438-3903 • Fax: (250) 984-0815
tekmarControls.com