

Engineering Specification

Job Name _____

Contractor _____

Job Location _____

Approval _____

Engineer _____

Contractor's P.O. No. _____

Approval _____

Representative _____

LEAD FREE*

MasterSeries®

LF870W/WZ

Double Check Valve Assembly

4" – 10"

FEBCO MasterSeries LF870W/WZ Double Check valve assembly is specifically designed to provide drop-in replacement of a competitor's valves in either the N-pattern (LF870W) or Z-pattern (LF870WZ) orientation. The assembly protects against possible backpressure and backsiphonage conditions for non-health hazard (pollutant) application in accordance with Local Governing Water Utility Code. This assembly is primarily used on potable drinking water systems where Local Governing Code mandates protection from non-potable quality water being pumped or siphoned back into the potable water system.

The iron components of the backflow preventer are coated with ArmorTek®, a patented three-part advanced epoxy system engineered to reduce microbial-induced corrosion (MIC) and protect exposed metal substrate. LF870W/WZ features Lead Free* construction to comply with low lead installation requirements. The Lead Free* assembly shall comply with state codes and standards, where applicable, requiring reduced lead content.

Features

- Longer gate-to-gate length for drop-in replacement of longer valves
- In-line serviceable assembly
- Vertical up/vertical down N-pattern installations
- Vertical up Z-pattern installations
- No special tools required for servicing
- Captured modular spring assembly
- Reversible and replaceable discs
- Field replaceable seats
- Ductile iron valve body esign
- Stainless steel check components
- ArmorTek coating technology to resist corrosion of internals
- Winterization feature with disc retainers and valve body drain ports
- Clapper check assembly
- Commonality between 1st and 2nd check components
- Captured O-ring design

*The wetted surface of this product contacted by consumable water contains less than 0.25% of lead by weight.



Specification

The Double Check valve assembly shall be designed to allow drop-in replacement of a competitor's valves in either the N-pattern (LF870W) or Z-pattern (LF870WZ) orientation. The assembly shall be installed on the potable water supply and at each point of cross-connection to protect against possible backpressure and backsiphonage conditions for non-health hazard (pollutant) applications. The assembly shall consist of a main line valve body composed of two (2) independently acting approved clapper style check modules with replaceable seats and disc rubbers. Servicing of both check modules shall not require any special tools and shall be accessed through independent top entry covers. This assembly shall be fitted with AWWA Compliant inlet/outlet resilient seated shutoff valves; when used on a Fire-Sprinkler application, the assembly shall be fitted with approved UL Classified/FM Approved inlet/outlet resilient seated shutoff valves and contain four (4) properly located resilient seated test cocks as specified by AWWA Standard C510. Iron components of the backflow preventer shall incorporate ArmorTek coating technology, delivering integrated protection against electrochemical corrosion and microbial-induced corrosion. The assembly shall be approved for horizontal and/or vertical-up installations while meeting the requirements of AWWA Standard C510 flow and pressure loss performance parameters. The assembly shall be FEBCO MasterSeries LF870W/WZ.

NOTICE

The information contained herein is not intended to replace the full product installation and safety information available or the experience of a trained product installer. You are required to thoroughly read all installation instructions and product safety information before beginning the installation of this product.

Inquire with governing authorities for local installation requirements.



A WATTS Brand

Model/Option

- OSY: UL Classified/FM Approved OS&Y Gate Valves (ANSI/AWWA C515 Compliant)
- NRS: Non-Rising Stem Gate Valves (ANSI/AWWA C509 Compliant)
- LG: Less Shutoff Valves; NOT an approved assembly

Example Ordering Description

4" LF870W-OSY - Valve Assembly fitted with OS&Y Shutoff Valves

Available Components

Wye Strainer: FDA Approved [ASME B16.1 Class 125 & AWWA Class D Flange]

Assembly Flow Orientation

Horizontal (N-pattern 4" – 10") - Approved by FCCCHR-USC, ASSE, cULus, FM, IAPMO

Vertical Up (Z-pattern 4" – 10") - Approved by FCCCHR-USC, ASSE, cULus, FM, IAPMO

Materials

- Main Valve Body: Ductile iron Grade 65-45-12
- Coating: ArmorTek powder coating, applied to internal and external surfaces
- Shutoff Valves: NRS resilient wedge gate valve AWWA C509 (Standard)
OSY resilient wedge gate valve AWWA C515 (UL/FM)
- Check Seats: Stainless steel
- Disc Holder: Stainless steel
- Elastomer Disc: Silicone
- Spring: Stainless steel
- Clamp: AWWA C606

Approvals – Standards

- Approved by the Foundation for Cross-Connection Control and Hydraulic Research at The University of Southern California (FCCCHR-USC)
- ASSE 1015 Listed
- UL Classified** (U.S. & Canada)
- FM Approved**
- IAPMO
- AWWA Standard C510 Compliant
- End Connections: Compliant to ASME B16.1 Class 125 & AWWA Class D Flange



Pressure - Temperature

- Max. Working Pressure: 175 psi (12.1 bar)
- Min. Working Pressure: 10 psi (0.7 bar)
- Hydrostatic Test Pressure: 350 psi (24.1 bar)
- Hydrostatic Safety Pressure: 700 psi (48.3 bar)
- Temperature Range: 33°F – 140°F (0.5°C – 60°C) continuous

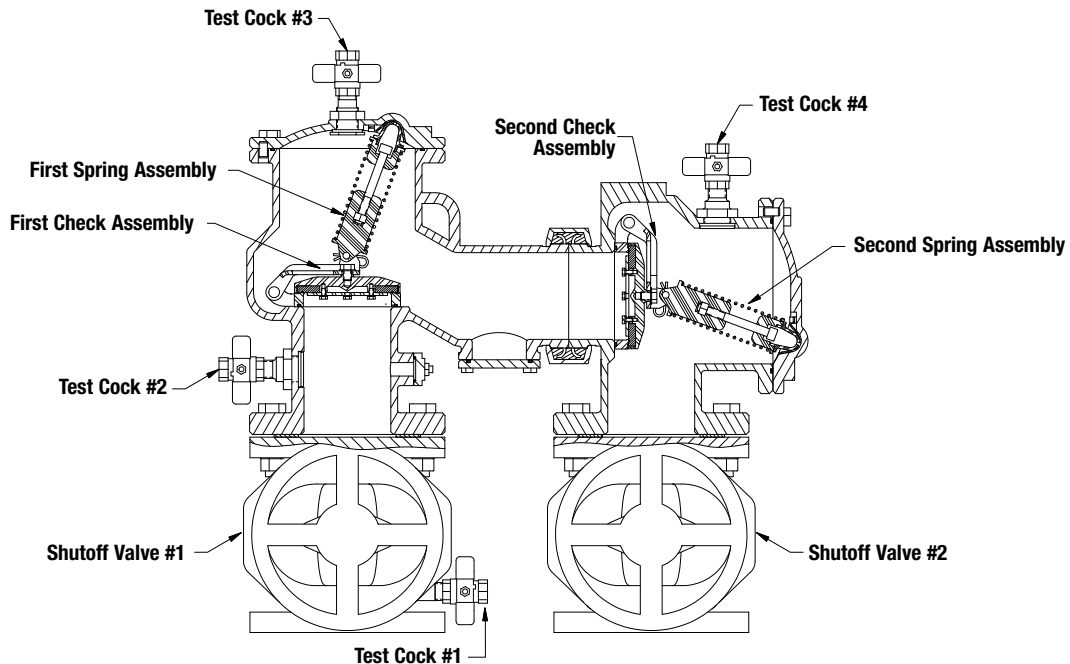

**Assembly configured with UL Classified/FM Approved OS&Y RW gate valves. Less gate valve assemblies are not UL Classified/FM Approved configurations.

Dimensions – Weights

Below are the nominal dimensions and physical weights for LF870W/WZ sizes 4" to 10". Allowances must be made for normal manufacturing tolerances. Visit watts.com to download the product manual, or contact your local FEBCO representative for more information.

LF870W Standard Orientation (N-Pattern)

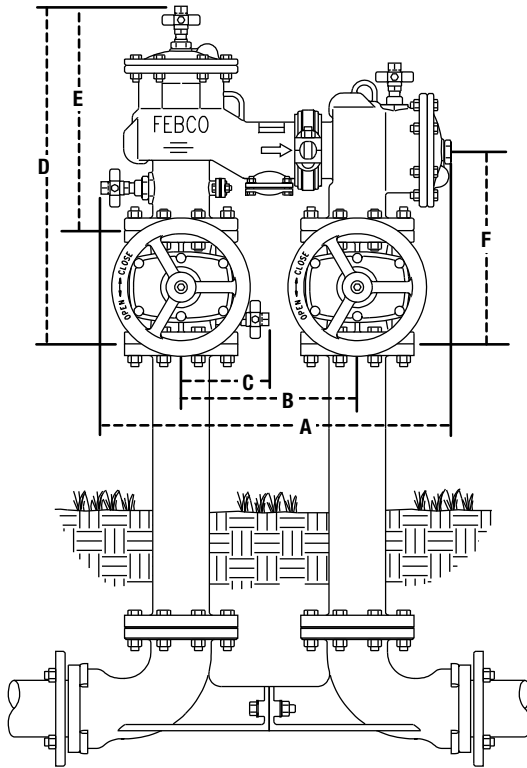

LF870WZ Vertical Orientation (Z-Pattern)

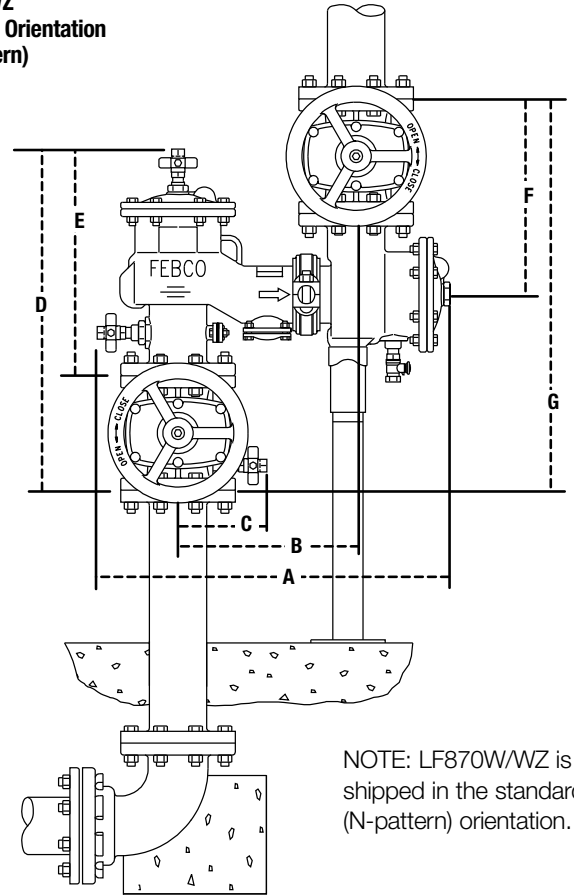

NOTE: LF870W/WZ is shipped in the standard (N-pattern) orientation.

Gate Valve Side View Clearance

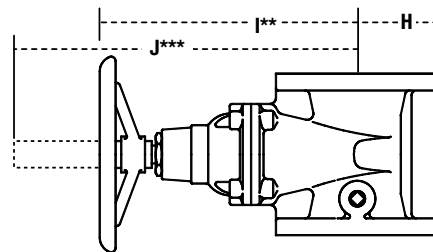

LF870W/WZ

SIZE	DIMENSIONS														WEIGHT****													
	A (W)		A (Z)		B (W)		B (Z)		C		D		E		F		G		H		I**		J***		NRS		OSY	
	in.	mm	in.	mm	in.	mm	in.	mm	in.	mm	in.	mm	in.	mm	in.	mm	in.	mm	in.	mm	in.	mm	in.	mm	lb	kg	lb	kg
4	32 ¹ / ₁₆	818	32 ¹ / ₁₆	833	18 ¹ / ₁₆	465	18 ¹ / ₁₆	481	7	178	26 ³ / ₁₆	680	17 ³ / ₁₆	451	15 ¹ / ₂	394	31	787	4 ¹ / ₂	114	14 ⁹ / ₁₆	365	22 ³ / ₁₆	591	320	145	332	151
6	34 ¹ / ₁₆	887	37 ¹ / ₁₆	946	18 ¹ / ₁₆	475	21	533	8	203	32 ¹ / ₁₆	819	21 ¹ / ₈	548	18 ⁵ / ₁₆	473	37 ¹ / ₁₆	946	5 ¹ / ₂	140	18 ⁷ / ₁₆	479	30 ¹ / ₈	765	492	223	512	232
8	48	1219	49 ⁹ / ₁₆	1253	29	737	30 ⁹ / ₁₆	770	9 ¹ / ₄	235	36 ³ / ₁₆	324	24 ⁷ / ₁₆	632	20 ³ / ₁₆	527	41 ¹ / ₂	1054	6 ³ / ₁₆	172	23 ¹ / ₂	597	37 ³ / ₁₆	959	782	355	810	367
10	50 ¹ / ₁₆	1272	51 ³ / ₁₆	1304	29	737	30 ⁹ / ₁₆	533	10 ¹ / ₁₆	264	40 ³ / ₁₆	1032	27 ¹ / ₂	699	23 ¹ / ₁₆	601	47 ⁹ / ₁₆	1202	8	203	27 ¹ / ₂	699	45 ³ / ₁₆	1162	-	-	1318	598

** Indicates nominal dimensions with NRS gate valves

*** Indicates nominal dimensions with OSY gate valves (full open position)

**** Indicates weight of complete backflow preventer assemblies with specified gate valves

Performance

Flow capacity chart identifies valve performance based upon rated water velocity up to 20 fps.

- Maximum service flow rate is determined by maximum rated velocity up to 7.5 fps
- AWWA Manual M-22 (Appendix C) recommends that the maximum water velocity in the services be no more than 10 fps
- UL flow rate is determined by typically rated velocity of 15 fps

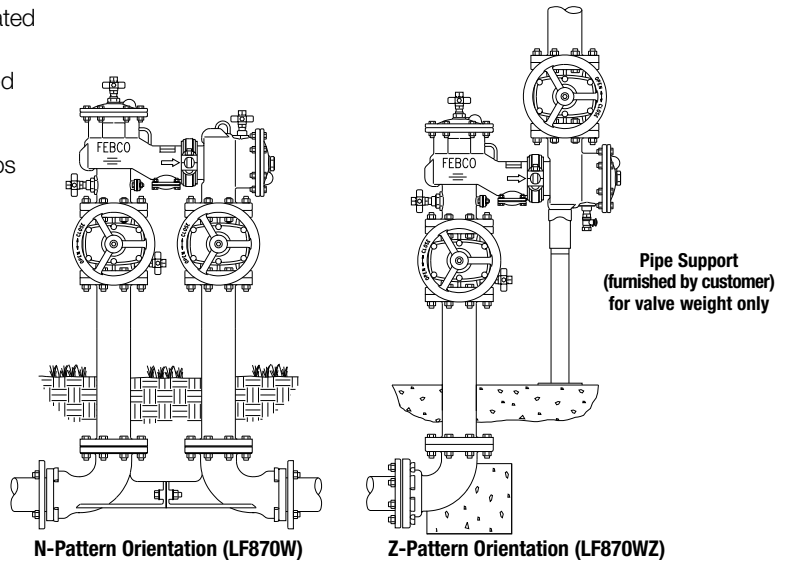

Capacity

LF870W (N-Pattern) LF870WZ (Z-Pattern)

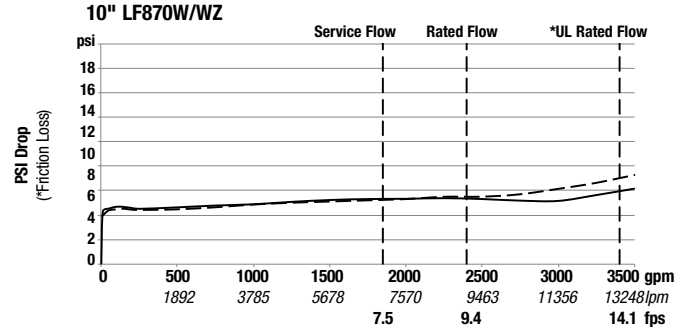
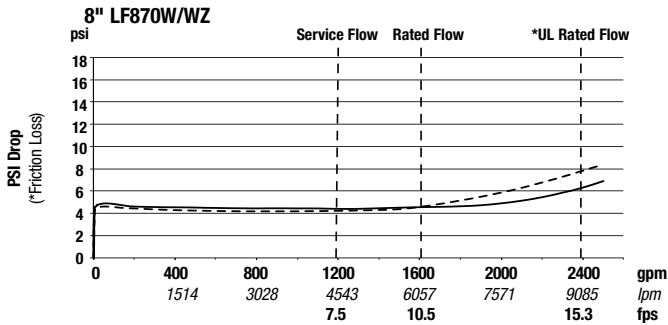
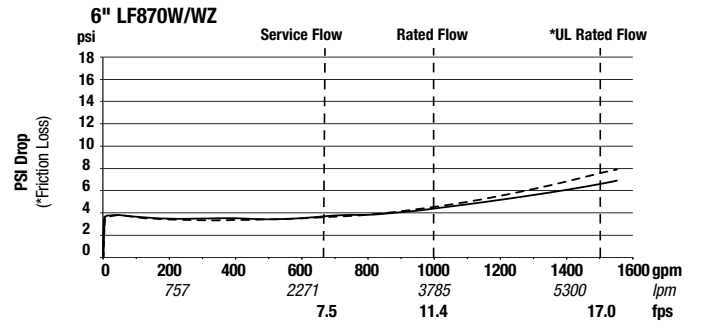
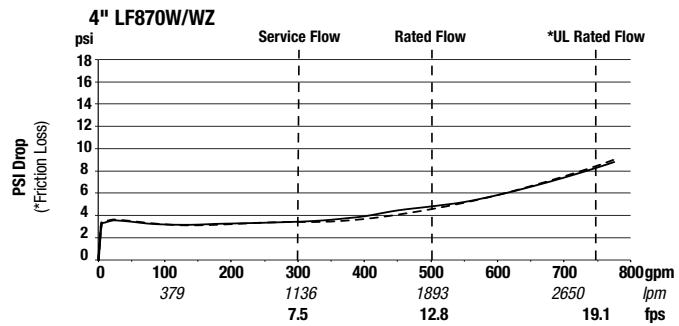

The 6" curves (N-standard orientation) include the FEBCO valve setter Series 611.



A WATTS Brand

USA: T: (800) 767-1234 • FEBCOonline.com
 Canada: T: (888) 208-8927 • FEBCOonline.ca
 Latin America: T: (52) 55-4122-0138 • FEBCOonline.com